

NBC 250GW

WELDING MACHINE



***USER MANUAL***

## Preface

This manual includes hardware description and operation introduction of the equipments. For your and other people's safety, please read the manual carefully.

### Pay attention

Pay attention to the words after the signs below.

Sign	Description
 DANGER	The words after this sign means there is great potential danger, which may cause major accident, damage or even death, if it is not followed.
 WARNING	The words after this sign means there is some potential danger, which may cause hurt or property lose, if it is not followed.
 ATTENTION	The words after this sign means there is potential risk, which may cause equipment fault or break, if it is not followed.

### Version

Version YF-TAE-0019, A2, Released on 16th, Aug., 2017.

The contents of this manual are updated irregularly for updating of product. The manual is only used as operation guide, except for other promises. No warranties of any kind, either express or implied are made in relation to the description, information or suggestion or any other contents of the manual.

The images shown here are indicative only. If there is inconsistency between the image and the actual product, the actual product shall govern.

# CONTENTS









1	Safety warning.....	4
2	Product .....	9
	2.1 General .....	9
	2.2 Technical data .....	10
3	Installation .....	13
4	Operation .....	17
	4.1 Front panel layout .....	17
	4.2 Operation instruction .....	20
	4.3 Welding environment and safety .....	21
	4.4 Welding problems and resolution .....	22
5	Daily maintenance and checking .....	23
6	Trouble shooting and fault finding .....	27
	Appendix I Welding parameter list.....	30
	Appendix II Circuit diagram .....	32
	Appendix III Component and list.....	35

# 1 Safety warning

The safety notes listed in this manual is to ensure correct use of the machine and to keep you and other people from being hurt.

The design and manufacture of welding machine considers safety. Please refer to the safety warning listed in the manual to avoid accidents.

Different damage would be caused by wrong operation of the equipment as follows. Please read the user manual carefully to reduce such damage.

Sign	Description
	<ul style="list-style-type: none"> <li>◇ Any contact of electric parts may cause fatal electric shock or burnt.</li> </ul>
	<ul style="list-style-type: none"> <li>◇ Gas and fumes are harmful to health.</li> <li>◇ Operation in narrow space may cause choke .</li> </ul>
	<ul style="list-style-type: none"> <li>◇ Spark and hot workpiece after welding may cause fire.</li> <li>◇ Bad connected cable may cause fire.</li> <li>◇ Incompletion connection of workpiece side circuit may cause fire.</li> <li>◇ Never weld on the case of tinder stuff, or it may cause explode.</li> <li>◇ Never weld airtight containers such as slot, pipe etc., or it may break.</li> </ul>
	<ul style="list-style-type: none"> <li>◇ Arc ray may cause eye inflammation or skin burnt.</li> <li>◇ Spark and residue will burn your eyes and skin.</li> </ul>
	<ul style="list-style-type: none"> <li>◇ Toppling over of the gas cylinder will cause body hurt.</li> <li>◇ Wrong use of the gas cylinder will lead to high-pressure gas eruption and cause human hurt.</li> </ul>
	<ul style="list-style-type: none"> <li>◇ Never let fingers, hair, clothes or etc. near the moving parts such as the fan.</li> </ul>
	<ul style="list-style-type: none"> <li>◇ The wire shoot out of the torch may stab eyes, face and other naked parts.</li> </ul>
	<ul style="list-style-type: none"> <li>◇ Never stand in front of the swang equipment or under it, or it may fail and cause injury.</li> </ul>



**DANGER**

**Please follow the rules below to avoid heavy accidents.**

- ~ Never use the equipment to do other things but welding.
- ~ Follow related regulations for the construction of the input-driven power source, choice of place, usage of high-pressure gas, storage, configuration, safe-keeping of workpiece after welding and disposal of waste, etc.
- ~ Nonessentials do not enter the welding area.
- ~ People using heart pacemaker is not allowed to get close to the welding machine or area without doctor's permission. The magnetism created by energizing the welding machine can have a bad effect to the pacemaker.
- ~ Install, operation, check and maintain the equipment by profession personnel.
- ~ Understanding the contents of the user manual for safety.



**DANGER**

**Please follow the rules below to avoid electric shock.**

- ~ Keep away from any electric parts.
- ~ Earth the machine and workpiece by professional personnel.
- ~ Cut off the power before installation or checking, and restart 5 minutes later. The capacitance is chargeable device. Please ensure it has no voltage before start again even if the power source is cut off.
- ~ Do not use wire with inadequate section surface or damage insulation sleeve or even exposed conductor.
- ~ Do ensure well isolation of wire connection.
- ~ Never use the device when the enclosure is removed.
- ~ Never use broken or wet insulation gloves.
- ~ Use firenet when work at high position.
- ~ Check and maintain regularly, don't use it until the broken parts are fixed well.
- ~ Turn off the power when not in used.
- ~ Follow the national or local related standard and regulations when using the AC welding machine at narrow or high position.



**DANGER**

**Please follow the below notes to avoid fire and explode, etc.**

- ~ No combustible in welding area.
- ~ Keep off combustible when welding.
- ~ Keep hot workpiece after welding away from flammable gas.
- ~ Do move away the combustible around when weld the dooryard, ground and wall,.
- ~ The wire connection of base metal should be as close to the welding place as possible.
- ~ Never weld those facilities with gas pipe or airtight slot.
- ~ Put fire extinguisher around the welding area to prevent fire.

 **WARNING** The gas and fumes are harmful to health, please wear protective device according to regulations.

- ~ Wear exhaust equipment and breathe preventive facilities to prevent gas poisoning or choke.
- ~ Use suggested part exhaust equipment and breathe preventive facilities to prevent hurt or poisoning by gas and other powder, please.
- ~ To prevent oxygen-deficiency, air out the gas-filled room which is full of CO<sub>2</sub> and argon on the bottom, When operating on trunks, boilers, cabins, etc.
- ~ Please accept the supervisor's inspection when operating in narrow space. Air the room and wear breathe preventive facilities.
- ~ Never operate in degrease, washing or spray space.
- ~ Using breathe preventive facilities when weld shielded steel for it will cause poisonous dust and gas.

 **WARNING** The arc, spark, residue and noise are harmful to health, please wear protective appliance.

- ~ Eye protection against arc is recommended when welding or supervise welding.
- ~ Please wear preventive spectacles.
- ~ Welder's gloves, welder's goggles, long sleeve clothes, leather apron, and other standard protection equipments must be worn for welding operation.
- ~ A screen to protect other people against the arc must be set in the welding place.

 **WARNING** Please follow the notes below to avoid gas cylinder toppling over or broken.

- ~ Use the gas cylinder correctly.
- ~ Use the equipped or recommended gaseous regulator.
- ~ Read the manual of gaseous regulator carefully before using it, and pay attention to the safety notes.
- ~ Fix the gas cylinder with appropriate holder and other relative parts.
- ~ Never put the cylinder under high temperature or sunshine environment.
- ~ Keep your face away from the gas cylinder exit when opening it.
- ~ Put on the gas shield when it is not used.
- ~ Never put the torch on the gas cylinder. The electrode can not meet the gas cylinder.

 **WARNING** Any touch of the switch part will cause injury, please note the following.

- ~ Never use the machine when the enclosure is off.
- ~ Install, operate, check and maintain the machine by professional person.
- ~ Keep your fingers, hair, clothes etc. away from the switch parts such as the fan.



**WARNING** The wire end may deal damage, please note the following.

- ~ Never look into the electric conduction hole when checking the wire feeding is normal or not, or the shooting wire may stab your eyes and face.
- ~ Keep your eyes, face or other naked parts away from the end of torch when feeding the wire manually or pressing the switch.



**ATTENTION** For better work efficiency and power source maintenance, please note the following.

- ~ Precautions against toppling over.
- ~ Never use the welding equipment for pipe thawing.
- ~ Lift the power source from side when use the up-down forklift truck to avoid toppling over.
- ~ When using the crane for lift, tie the rope to the ears with an angle no more than  $\phi 15$  to the vertical direction.
- ~ When lifting the welding machine which equipped with gas cylinder and wire feeder, download them from the power source and ensure the horizontal of the machine. Do fix the gas cylinder with belt or chain when moving it to avoid body hurt.
- ~ Ensure fastness and insulation when lifting the wire feeder through the swing ring for welding.



**ATTENTION** Electromagnetic interference needing attention:

- ~ It may need extra preventive measures when the equipment is used in particular location.
- ~ Before the installation, please estimate the potential electromagnetism problems of the environment as follows.
  - a) Upper and lower parts of the welding equipments and other nearby power cable, control cable, signal cable and phone cable.
  - b) Wireless electric as well as TV radiation and reception equipment.
  - c) Computer and other control equipments.
  - d) Safety-recognition equipment etc. Such as supervise of industrial equipments.
  - e) Health of people around. Such as personnel using the heart pacemaker or audiphone.
  - f) Equipments for adjustment and measurement.
  - g) Anti-disturb capability of other used equipments .Users should ensure these equipments and the environment are compatible, which may need extra preventive measures.
  - h) Practical state of the welding and other activities.

- ~ Users should observe the following dos and don'ts to decrease radiation interference.
  - a) Connect the welding equipments to the power supply lines.
  - b) Maintain the welding equipments regularly.
  - c) The cable should be short enough to be close to each other and the ground.
  - d) Ensure the safety of all the welding metal parts and other parts nearby.
  - e) The workpiece should be well earth.
  - f) Shield or protect the other cable and equipments to decrease the effects of disturbances. The welding equipments can be complete shielded in some special conditions.
- ~ Users are responsible for interference due to welding.



## 2 Product

### 2.1 General

MIG CO<sub>2</sub> gas shielded welding machines of our company are inverter welding machines manufactured by our company applying most advanced inversion technology in the world.

Their principle is to commutate the power frequency of 50Hz/60Hz into direct current, and then utilize the high-power device IGBT to invert it into high frequency (15 KHz/16KHz), then perform voltage-drop and commutate, and output high-power D.C power supply via Pulse Width Modulation (PWM). Since the switch power inversion technology is adopted, the weight and volume of the welding machine is brought down greatly with a conversion efficiency increase of more than 30%. Characteristic: stable wire feed rate, little splatter, portable, energy-saving, low electromagnetic noise.

The CO<sub>2</sub> gas shielded welding machine of our company is equipped with unique electronic reactor circuit, precisely controlling the short-circuiting transfer and mixed transfer of welding, producing excellent welding characteristic. Compared with silicon controlled welding machine and welder with taps, our products have the following merits: stable wire feed rate, portable, energy-saving, electromagnetic noise free. Besides, our products have merits such as electric network fluctuation self-compensation function, little splatter, good arc starting, deep welding pool, high duty cycle etc. This equipment can be applicable in large-scale plants such as shipyards, steel structure plants etc. featuring high efficiency and energy-saving.

The CO<sub>2</sub> gas shielded welding machine of our company has function of ending arc On/Off. Arc starting current and ending arc current can be adjusted separately, being very applicable for automatic welding. This machine is most suitable for the welding of mild steel, alloy steel and stainless steel.

Thank your for choosing our products. Please feel free to propose your valuable suggestions; we will make efforts to perfect our products and service.



**The machine is mainly used in industrial fields. It will cause radion interference if used indoors. Please take through precaution measures.**

---

## 2.2 Technical data

Model	NBC 250GW		
Parameters			
Power voltage (V)	3 phase AC380V±15%	3 phase AC415V±15%	3 phase AC440V±15%
Frequency (Hz)	50/60	50/60	50/60
Rated input current (A)	14 (MIG) 16 (MMA)	12 (MIG) 14 (MMA)	11 (MIG) 13 (MMA)
Output current adjust(A)	40-250 (MIG) 60-250 (MMA)	40-250 (MIG) 60-250 (MMA)	40-250 (MIG) 60-250 (MMA)
Output voltage (V)	16-26.5 (MIG) 22.4-30 (MMA)	16-26.5 (MIG) 22.4-30 (MMA)	16-26.5 (MIG) 22.4-30 (MMA)
No-load voltage(V)	56	61	62
Duty cycle (%)	30 (MIG) 30 (MMA)		
Power factor	0.93		
Efficiency (%)	85		
Type of wire feeder	Compact		
No-load loss(W)	120		
Wire feed speed (m/min)	3-13		
Post flow time (s)	1.0±0.5		
Welding-wire diameter (mm)	0.8/1.0		
Insulation grade	F		
Housing protection grade	IP21		
Welding thickness (mm)	More than 0.8		
Weight (kg)	23		
Overall dimension L*W*H (mm)	478*253*485		

### 3 Installation

The welding equipment is equipped with power voltage compensation device. It keeps the machine work normally when power voltage fluctuating  $\pm 15\%$  of rated voltage.

When using long cable, in order to reduce voltage drop, big section cable is suggested. If the cable is too long, it will affect the performance of arcing and other system function, it is suggested to use the recommend length.

- Make sure the intake of the machine is not covered or blocked to avoid the malfunction of the cooling system.
- Make sure the earth end of power interface has been reliably and independently grounded.
- Connect the main circuit cable of the wire feeder to the corresponding output end of the machine, and fasten with bolts.
- Connect the plug of the control circuit 6-core cable of the wire feeder to the corresponding interface of the machine and lock.
- Connect the plug of earth wire to the corresponding output end of the machine, and fasten with bolts.
- Install the CO<sub>2</sub> gas meter on the gas cylinder; connect the trachea of the wire feeder to the CO<sub>2</sub> gas meter tightly.
- Plug the welding gun to the welding gun output socket of the wire feeder and rotate 45° clockwise. Tighten the welding gun fastening screws with in turn spanner so as that the welding gun contacts with the wire feeder output socket reliably. Connect the controller plug and the gas connection to the wire feeder.
- Install the wire reel loaded with welding wire on the shaft bracket of the wire feeder, select different wire feeding groove according to the welding wire diameter.
- Loosen the pressure arm, feed the welding wire into wire feeding pipe through gadget wheel and groove. Press the pressure arm so that the wire pressing wheel presses the welding wire tightly to prevent the welding wire from sliding. Do not push the pressure arm too hard; prevent the welding wire from deformation and interfering with wire feeding. The welding wire roll rotates clockwise to loosen the welding wire. In order to prevent the leading end of wire reel from loosening, it is generally fixed to the fixing hole of the wire reel. Cut off this part of welding wire to prevent the winding welding wire from getting struck during normal operation.

**Explanatory drawing for Installation of MIG 250GW (MIG)**

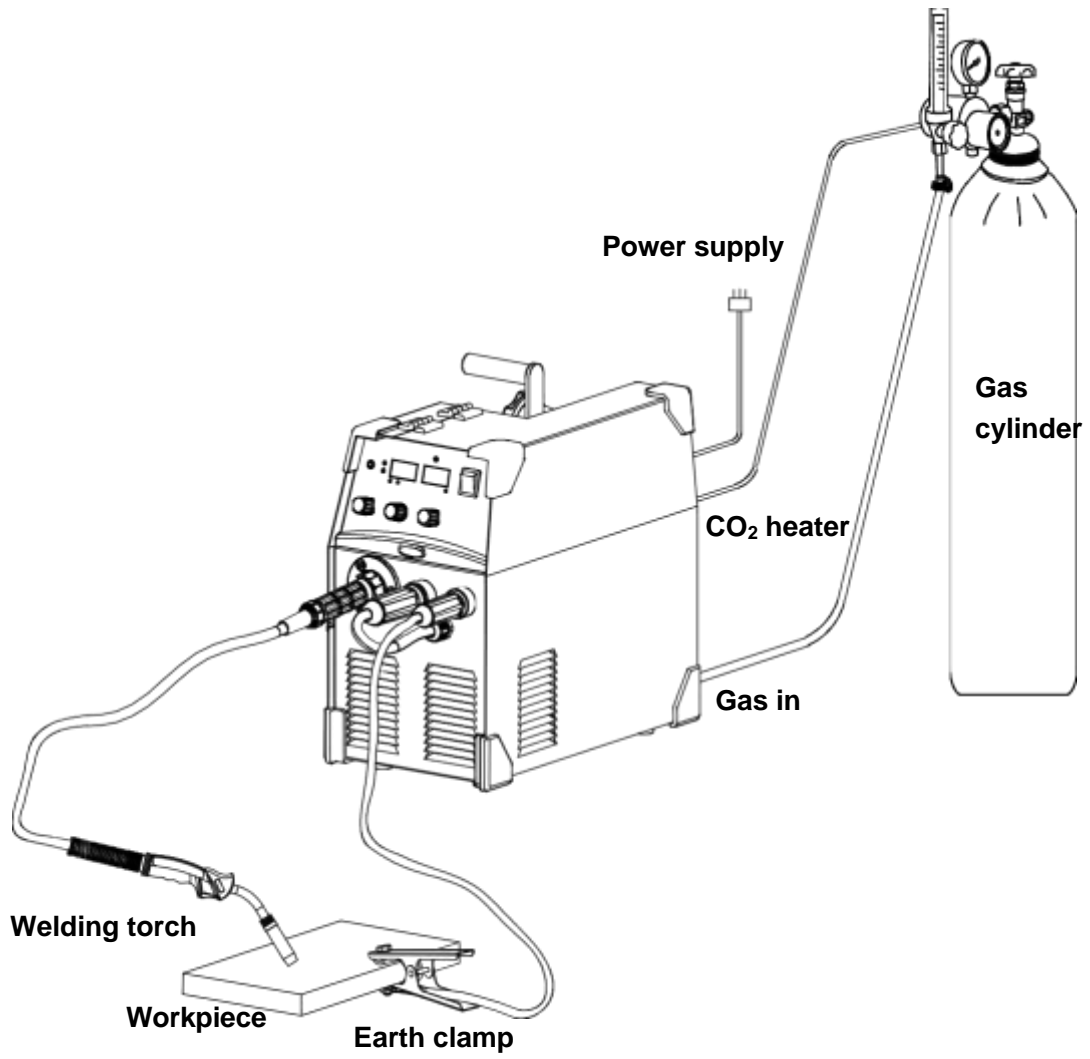

**Explanatory drawing for Installation of MIG 250GW (MMA)**

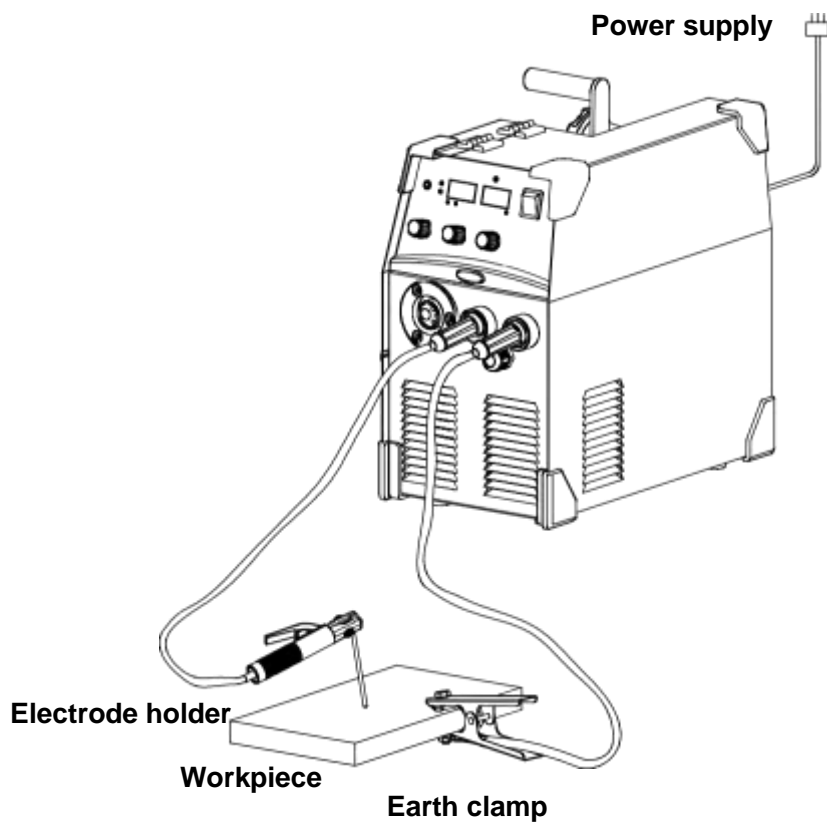

Notes: Turn the welding machine to MMA mode for heating the gas cylinder to prevent CO2 meter icing when the machine is not working under MIG mode.

The series of machine is customized to fixed with wire coil cover to protection the wire coil. The installation steps for it is as follows.

Step 1. Please fix the parts to the wire coil base on the welding power source as fig. 1.

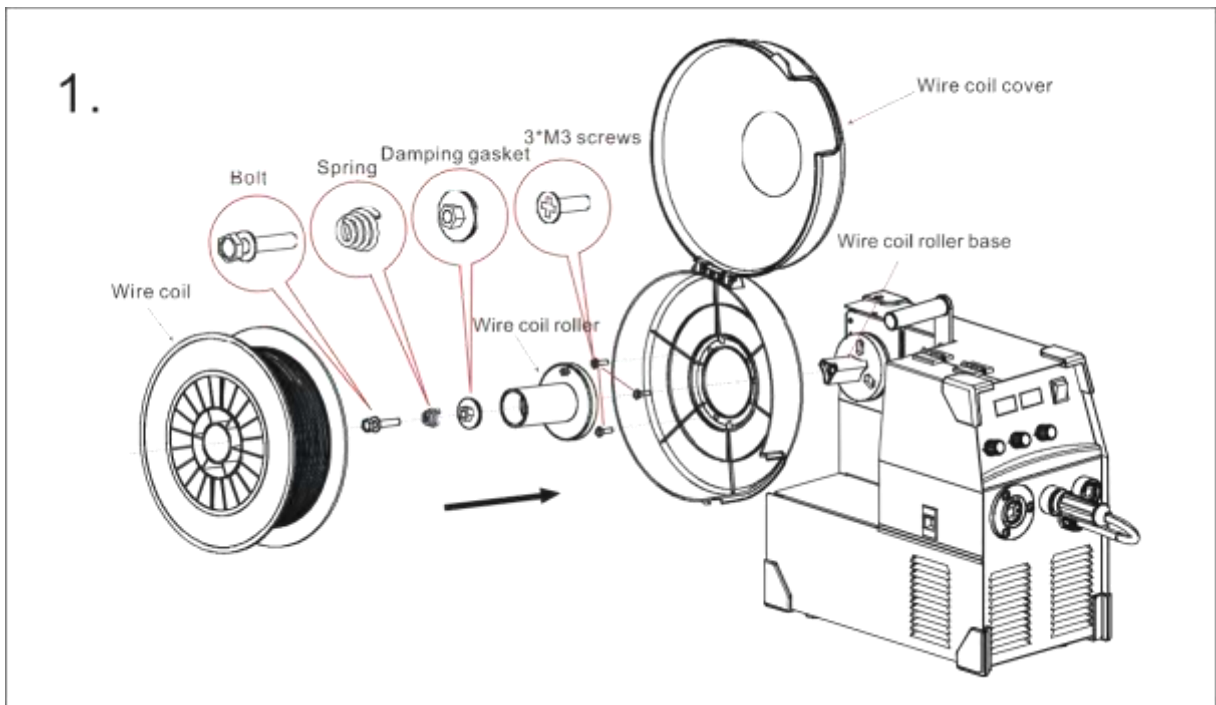

Step 2. Please fix the cover of wire coil roller as fig. 2.

Step 3. Close the wire coil cover as fig.3, the installation is finished.

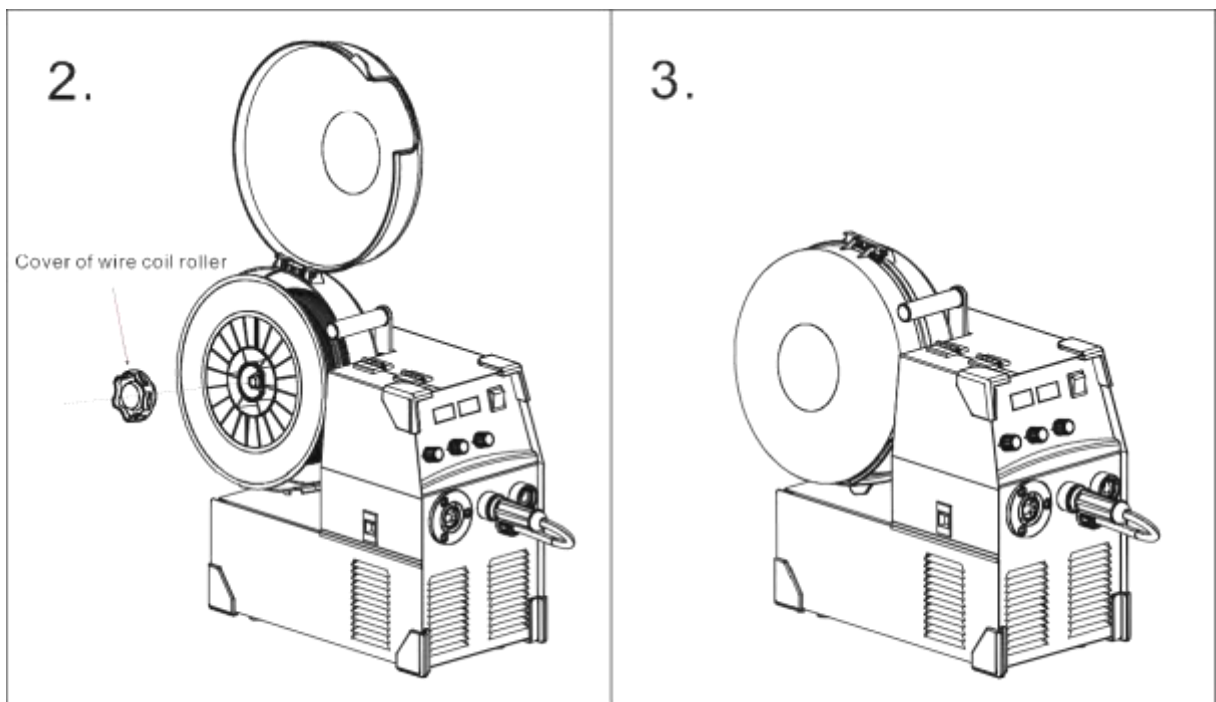

## 4 Operation

### 4.1 Front panel layout

MIG 250GW Front Panel

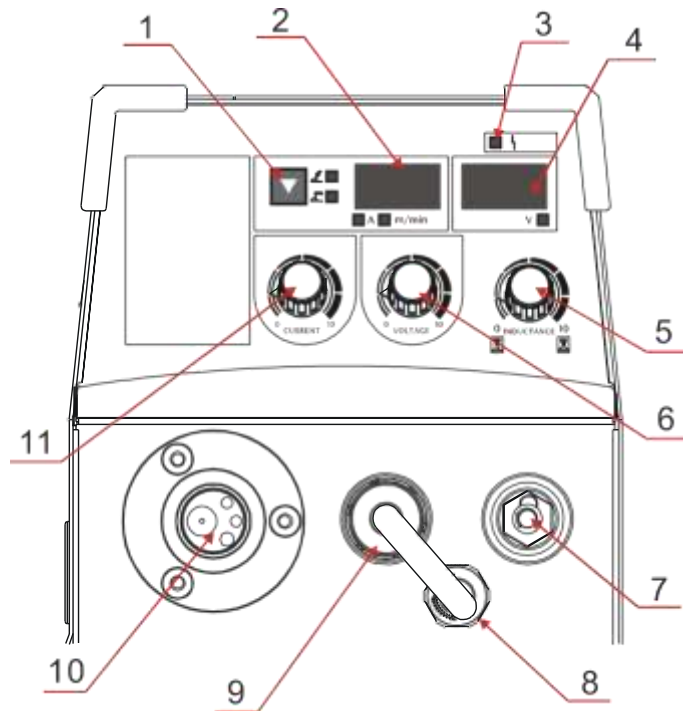

1	MIG/MMA changeover button
2	Current/ wire speed meter
3	Abnormal indicator
4	Voltage meter
5	Inductance adjust knob
6	Welding voltage adjustment knob
7	Negative output terminal
8	Output polarity conversion joint
9	Positive output terminal
10	Welding torch output terminal
11	Welding current adjustment knob

The images shown here are indicative only. The actual product may differ.

## 4.2 Operation instruction

- Change-over switch

- a) Gas examining/welding change-over switch: When this switch is in the gas examining position, the gas supply of the welding machine is examined. When this switch is in the welding position, the welding machine is in the normal welding state.
- b) 2T/4T changeover switch: When put to "2T" position, press torch switch to weld. When put to "4T" position, press hand switch to start machine, undo the torch, machine is on welding situation, press the torch switch again, it stops.
- c) Welding diameter change-over switch: When welding wires of different diameter are used, the switch shall be in the corresponding position correctly.

- Adjusting knob

- a) Welding voltage adjustment: this knob is used to adjust the output voltage.
- b) Welding current adjustment: this knob is used to adjust the output current.
- c) Inductance adjustment: The softness and hardness level of the electric arc can be adjusted to achieve best welding effect. When the current is small, the electric arc shall be hard to reduce arc interruption. When large current, the electric arc shall be soft so as to reduce splatter.

- Polarity conversion joint

This machine has the polarity conversion; There are positive output terminal and negative output terminal between wire feeder and wire spool; When use solid wire with gas protection, torch socket should be connected to the positive output terminal, ground cable should be connected to the negative output terminal; When use flux-cored wire, the two connected cable should be exchanged.

- Notice

The machine has the function of limited current, when the over-current, it would react, prevent the machine was damaged from over-current. So, you must select recommendatory Welding diameter and reasonable range of welding current.



### 4.3 Welding environment and safety

- **Environment**

- a) The machine can perform in environment where conditions are dry with a dampness level of max 90%.
- b) Ambient temperature is between -10 to 40 degrees centigrade.
- c) Avoid welding in sunshine or drippings. Do not let water enter the gas
- d) Avoid welding in dust area or the environment with corrosive gas.
- e) Avoid gas welding in the environment with strong airflow.

- **Safety norms**

Our welding machine has installed protection circuit of over voltage, over current and over heat. When voltage, output current and temperature of machine are exceeding the rate standard, welding machine will stop working automatically. Because that will be damage to welding machine, user must pay attention to following.

- a) **The working area is adequately ventilated !**

Our welding machine is powerful machine, when it is being operated, it generated by high currents, and natural wind can't be satisfied with machine cool demands. So there is a fan in inter-machine to cool down machine. Make sure the intake is not in block or covered, it is 0.3 meter from welding machine to objects of environment. User should make sure the working area is adequately ventilated. It is important for the performance and the longevity of the machine.

- b) **Do not over load !**

The operator should remember to watch the max duty current (Response to the selected duty cycle).Keep welding current is not exceed max duty cycle current. Over-load current will damage and burn up machine.

- c) **No over voltage !**

Power voltage can be found in diagram of main technical data. Automatic compensation circuit of voltage will assure that welding current keeps in allowable range. If power voltage is exceeding allowable range limited, it is damaged to components of machine. The operator should understand this situation and take preventive measures.

- d) There is a grounding screw behind welding machine, with a grounding marker on it. Before operation, welding crust must be grounded reliable with cable which section is over 6 square millimeters, in order to prevent from static electricity, and accidents because of electricity leaking.
- e) If welding time is exceeding duty cycle limited, welding machine will stop working for protection. Because machine is overheated, temperature control switch is on "ON" position and the indicator light is red. In this situation, don't pull the plug, let the fan cool the machine. When the indicator light is off, and the temperature goes down to the standard range, it can weld again.

## 4.4 Welding problems and resolution

The phenomenon listed below may happen due to relevant accessories used, welding material, surroundings and power supply. Please improve surroundings and avoid these problems..

- **Arc starting difficulty. Arc interruption happens easily:**

- a) Examine whether grounding wire clamp contacts with the work pieces well.
- b) Examine whether each joint has improper contact.

- **The output current fails to reach rated value:**

The deviation of power voltage from rated value may cause that the output current does not accord with adjusted value. When the power voltage is lower than rated value, the maximum output current may be lower than rated value.

- **The current can not keep stable during operation:**

This situation may relate to the following factors:

- a) The voltage of electric power network changes;
- b) Serious interference from electric power network or other electric facilities.

- **Gas vent in welds:**

- a) Examine whether the gas supply circuit has leakage.
- b) Examine whether there is sundries such as oil, dirt, rust, paint etc. on the surface.

## 5 Daily maintenance and checking

- **Daily maintenance**

- a) Remove dust regularly with dry compressed air. If the welding machine is used in surroundings with heavy smoke and polluted air, it is necessary to remove dust at least one time one month.
- b) The pressure of compressed air shall fall to required level to prevent damage to small components in the machine.
- c) Examine inside electric joints and ensure perfect contact (Especially plugs and sockets). Fasten the loosing joints. In case of oxidation, remove oxide film with sand paper and connect again.
- d) Prevent water from entering into the machine and prevent the machine from getting moist. If any, blow and dry. Measure the insulation with megohmmeter to make sure it is qualified to use.
- e) If the welding machine is not used for a long time, pack the machine in original package and store in dry surroundings.
- f) Every time the wire feeder operates for 300hours, grind the electrical carbon brush and clear up the armature commutator. Rinse speed reducer, apply 2# Molybdenum Disulfide lubricant to the turbine, whirlpool rod and bearing.



**The power shall be cut off completely before all maintenance, repairing works. Make sure to pull out power plug before opening the case.**

---

- **Daily checking**

<b>WELDING POWER SUPPLY</b>		
Position	Checking keys	Remarks
Control panel	<ul style="list-style-type: none"> <li>➤ Switch condition of operation, transfer and installation.</li> <li>➤ Test the power indicator.</li> </ul>	
Cooling fan	<ul style="list-style-type: none"> <li>➤ Check if there is wind and the sound normal or not.</li> </ul>	If abnormal noise and no wind, to check the inner.
Power part	<ul style="list-style-type: none"> <li>➤ When electrified, abnormal smell or not.</li> <li>➤ When electrified, abnormal vibration and buzz or not.</li> <li>➤ Color changing and heating or not in appearance.</li> </ul>	
Periphery	<ul style="list-style-type: none"> <li>➤ Gas pipe broken, loosen or not.</li> <li>➤ Housing and other fixed parts loosen or not.</li> </ul>	

<b>WELDING TORCH</b>		
Position	Checking keys	Remarks
Loophole	<ul style="list-style-type: none"> <li>➤ If installment fixed, the front distorted</li> </ul>	Reason for air hole.
	<ul style="list-style-type: none"> <li>➤ Attach splash or not.</li> </ul>	Reason for burning the torch. (can use splash-proof material )
Electric hole	<ul style="list-style-type: none"> <li>➤ If installment fixed</li> </ul>	Reason of torch screw thread damage
	<ul style="list-style-type: none"> <li>➤ Damage of its head and hole blocked nor not</li> </ul>	Reason of unstable arc and broken arc
Wire sending tube	<ul style="list-style-type: none"> <li>➤ Check the extended size of the pipe</li> </ul>	Have to be changed when less than 6mm, when the extended part too small, the arc will be unstable.
	<ul style="list-style-type: none"> <li>➤ Wire diameter and the tube inner diameter match or not</li> </ul>	Reason of unstable arc, please use the suitable tube.
	<ul style="list-style-type: none"> <li>➤ Partial winding and extended</li> </ul>	Reason of poor wires sending and unstable arc, please change.

	<ul style="list-style-type: none"> <li>➤ Block caused by dirt in the tube, and the remains of the wire plating lay.</li> </ul>	Reason of poor wire sending and unstable arc, (use kerosene to wipe or change new one.)
	<ul style="list-style-type: none"> <li>➤ Wire sending tube broken O circle wear out</li> </ul>	<ol style="list-style-type: none"> <li>1. Pyrocondensation tube broken, change new tube</li> <li>2. Change new O circle</li> </ol>
Gas bypass	Forget to insert or the hole blocked, or different factory component.	May lead to vice (splash) because of poor gas shield, torch body get burned (arc in the torch), please handle.

<b>WIRE SENDING MACHINE</b>		
Position	Checking keys	Remarks
Pressing arm	<ul style="list-style-type: none"> <li>➤ If put the arm to the suitable indicating level. (notes : not to damage wire less than <math>\Phi 1.2\text{mm}</math> )</li> </ul>	Lead to unstable arc and wire sending.
Wire lead tube	<ul style="list-style-type: none"> <li>➤ If powder or residue store up in the mouth of the tube.</li> </ul>	Clean the residue and check the reason and solve it.
	<ul style="list-style-type: none"> <li>➤ Wire diameter and the tube inner diameter match or not</li> </ul>	If not match, lead to unstable arc and residue.
	<ul style="list-style-type: none"> <li>➤ If the tube mouth center matches the wire wheel slot center or not.</li> </ul>	If unmatched, lead to unstable arc and residue.
Wire wheel	<ul style="list-style-type: none"> <li>➤ Wire diameter matches the wheel's requirement</li> <li>➤ If the wheel slot blocked.</li> </ul>	<ul style="list-style-type: none"> <li>➤ Lead to unstable arc and residue, and block wire tube.</li> <li>➤ Change new one of necessary.</li> </ul>
Pressure wheel	Check the stability of its move, and wearing-out of pressed wire, the narrowing of its contact surface	Lead to unstable arc and wire sending.

CABLE		
Position	Checking keys	Remarks
Torch cable	<ul style="list-style-type: none"> <li>➤ If torch cable over bended.</li> <li>➤ If the metal connecting point of mobile plug loosen.</li> </ul>	<ul style="list-style-type: none"> <li>➤ Cause poor wire sending.</li> <li>➤ Unstable arc if cable over bended.</li> </ul>
Output cable	<ul style="list-style-type: none"> <li>➤ Wearing-out of the cable insulated material.</li> <li>➤ Cable connecting head naked(insulation damage),or loosen(the end of power supply, and cable of main material connecting point.)</li> </ul>	<p>For life security and stable welding, adopt suitable method to check according to working place.</p> <ul style="list-style-type: none"> <li>➤ Simple check daily</li> <li>➤ Careful and in-depth check on fixed period</li> </ul>
Input cable	<ul style="list-style-type: none"> <li>➤ If the connect of power supply input, protective equipment input and the output end fixed or not.</li> <li>➤ If the security equipment cable reliably connected.</li> <li>➤ If the power input end cable fixed.</li> <li>➤ If the input cable is worn out and bares the conductor.</li> </ul>	
Earth cable	<ul style="list-style-type: none"> <li>➤ If the earth cable that connects the power supply is broken and connect tightly.</li> <li>➤ If the earth cable that connects the main part is broken and connects tightly.</li> </ul>	<p>To prevent creep age and insure security, please make daily check.</p>

## 6 Trouble shooting and fault finding

**Notes:** The following operations must be performed by qualified electricians with valid certifications. Before maintenance, you are suggested to contact local distributor to verify qualification.

### Malfunctions and solutions

Malfunctions	Solution
<p>The meter show nothing;</p> <p>Fan does not rotate;</p> <p>No welding output</p>	<ol style="list-style-type: none"> <li>1. Confirm the power switch is on.</li> <li>2. Power supply available for input cable.</li> <li>3. Check if the commute bridge is damaged.</li> <li>4. There is malfunction occurs in the supplementary power source on control board (contact dealers).</li> </ol>
<p>The meter shows;</p> <p>Fan works normally;</p> <p>No welding output</p>	<ol style="list-style-type: none"> <li>1. Check if all the sockets in the machine are connected well.</li> <li>2. There is open circuit or badness of connect at the joint of output terminal.</li> <li>3. The control cable on the torch is broken off or the switch is damaged.</li> <li>4. The control circuit is damaged.(contact to dealers)</li> </ol>
<p>the meter shows;</p> <p>Fan works normally;</p> <p>Abnormal indicator lights.</p>	<ol style="list-style-type: none"> <li>1. It might be over-current protection, please turn off the power switch; restart the machine after the abnormal indicator light winked.</li> <li>2. It might be overheating protection, please wait for about 2-3 minutes until the machine renew without turn off the power switch.</li> <li>3. It might be multifunction of inverter circuit. (contact dealers)</li> </ol>

## INITIAL PROBLEMS DIAGNOSE

Even the machine comes up with abnormal phenomenon such as welding unable, arc unstable or bad welding effect, it is still early to judge that there is malfunction on the machine.

The above-mentioned abnormal phenomenon may be caused by some reasons. For example: tight parts loosen, forgetting to switch on, wrong set up, cable broken and gas rubber pipe cracked, etc. Therefore, please test and inspect these factors before deliver it back to the factory because a large number of troubles may be easily solved probably.

For this reason, an initial diagnosis list for general welding troubles is shown below. A trouble happened may be found in the column of "Abnormal items" on up-right of the list, please inspect and maintain for the corresponding items which have "○" mark in the column according to the following list respectively.

### Initial problems diagnose

Area and Item to be Inspected and Maintained		Abnormal Items								
		No arch Arc Starting	No Gas out	No Wire Feeding	Bad Arc Ignition	Unstable Arc	Dirt on Edge of Weld Seam	Wire Stick to Parent material	Wire Stick to Conductive Tip	Blowhole Formed
Distribution Boxes (Input Protection Devices)	<ol style="list-style-type: none"> <li>1. Turn on power supply or not?</li> <li>2. Fuse burnt out</li> <li>3. Connection joint loose</li> </ol>	○	○	○	○	○	○			
Input Cable	<ol style="list-style-type: none"> <li>1. Examine whether the cable is cut off.</li> <li>2. Connection joint loose</li> <li>3. Over heat</li> </ol>	○			○	○	○			
Welding Power Operation	<ol style="list-style-type: none"> <li>1. Turn on power supply or not?</li> <li>2. Phase Lacking</li> </ol>	○	○	○	○	○	○	○		
Gas Cylinder and Gas Regulator	<ol style="list-style-type: none"> <li>1. Turn on gas supply</li> <li>2. Residual Amount of Gas in the Cylinder</li> <li>3. Set value for flow</li> <li>4. Connection joint loose</li> </ol>					○			○	
Gas supply hose (the whole line from the high pressure cylinder to the weld gun)	<ol style="list-style-type: none"> <li>1. Connection joint loose</li> <li>2. Gas hose damaged</li> </ol>								○	



### Initial problems diagnose

Area and Item to be Inspected and Maintained	Abnormal Items	No arch	No Gas out	No Wire Feeding	Bad Arc Ignition	Unstable Arc	Dirt on Edge of Weld Sea	Wire Stick to Parent material	Wire Stick to Conductive Tip	Blowhole Formed
Wire Feeding Device	<ol style="list-style-type: none"> <li>1. Wire feeding wheel does not match with the diameter of wire in texturing tube</li> <li>2. Crackle on wire feeding wheel, groove blocked up or defect</li> <li>3. Too tight or loose of the handle</li> <li>4. Wire powder accumulated on the inlet of SUS pipe</li> </ol>			<input type="radio"/>	<input type="radio"/>	<input type="radio"/>	<input type="radio"/>	<input type="radio"/>		
Weld Gun and Cable	<ol style="list-style-type: none"> <li>1. Weld gun cable rolled up or over curved</li> <li>2. Adaptability of conductive tip, wire feeding pipe and cable diameter Worn, blocked up or deformation, etc.</li> </ol>				<input type="radio"/>	<input type="radio"/>	<input type="radio"/>	<input type="radio"/>		
Body of weld gun	<ol style="list-style-type: none"> <li>1. Loose connection of conductive tip, nozzle and nozzle contactor</li> <li>2. Contactor of weld gun body is not plunged in or tightened well</li> </ol>					<input type="radio"/>			<input type="radio"/>	
Power supply cable of weld gun as well as cable of switch control	<ol style="list-style-type: none"> <li>1. Break off (bending fatigue)</li> <li>2. Damaged by weighted drop</li> </ol>	<input type="radio"/>	<input type="radio"/>	<input type="radio"/>		<input type="radio"/>	<input type="radio"/>			
Surface Condition of Parent material and length that wire stretches out	<ol style="list-style-type: none"> <li>1. Oil, dirty, rust and paint residues</li> <li>2. Too long length of wire stretched out</li> </ol>				<input type="radio"/>	<input type="radio"/>	<input type="radio"/>	<input type="radio"/>	<input type="radio"/>	
Output Cable	<ol style="list-style-type: none"> <li>1. Cross-section of cable that connects to parent material is not enough</li> <li>2. Loose connection of (+) , (-) output cable</li> <li>3. Bad electric conductivity of parent material</li> </ol>				<input type="radio"/>	<input type="radio"/>	<input type="radio"/>			
Lengthened Cable	<ol style="list-style-type: none"> <li>1. Cross-section of cable is not enough</li> <li>2. It is rolled up or folded</li> </ol>				<input type="radio"/>	<input type="radio"/>	<input type="radio"/>	<input type="radio"/>		
Work Condition for Welding	Welding current, voltage, angle of weld gun, welding rate and wire length stretched out should be confirmed once again				<input type="radio"/>	<input type="radio"/>	<input type="radio"/>	<input type="radio"/>	<input type="radio"/>	

## Appendix I Welding parameter list

- Generally, welding current is adequate to welding electrode according with as following.

Electrode specification	φ2.5	φ3.2	φ4.0	φ5.0
Welding current	50-90A	90-130A	140-210A	190-270A

- Welding variables when use MIG welding

The values listed in the following table are the general specification values under standard condition.

		Plate thickness (mm)	Wire diameter (mm)	Interval (mm)	Current (A)	Voltage (V)	Welding speed (cm/min)	Wire extension (mm)	Gas flow rate (L/min)
I Square butt welding	Low welding speed	0.8	0.8,0.9	0	60~70	16~16.5	50~60	10	10
		1.0	0.8,0.9	0	75~85	17~17.5	50~60	10	10~15
		1.2	0.8,0.9	0	80~90	16~16.5	50~60	10	10~15
		1.6	0.8,0.9	0	95~105	17~18	45~50	10	10~15
		2.0	1.0,1.2	0~0.5	110~120	18~19	45~50	10	10~15
		2.3	1.0,1.2	0.5~1.0	120~130	19~19.5	45~50	10	10~15
		3.2	1.0,1.2	1.0~1.2	140~150	20~21	45~50	10~15	10~15
		4.5	1.0,1.2	1.0~1.5	160~180	22~23	45~50	15	15
			1.2	1.2~1.6	220~260	24~26	45~50	15	15~20
			1.2	1.2~1.6	220~260	24~26	45~50	15	15~20
		1.2	1.2~1.6	300~340	32~34	45~50	15	15~20	
		1.2	1.2~1.6	300~340	32~34	45~50	15	15~20	
	High welding speed	0.8	0.8,0.9	0	100	17	130	10	15
		1.0	0.8,0.9	0	110	17.5	130	10	15
		1.2	0.8,0.9	0	120	18.5	130	10	15
		1.6	1.0,1.2	0	180	19.5	130	10	15
2.0		1.0,1.2	0	200	21	100	15	15	
2.3		1.0,1.2	0	220	23	120	15	20	
3.2		1.2	0	260	26	120	15	20	

		Plate thickness (mm)	Wire diameter (mm)	Current (A)	Voltage (V)	Welding speed (cm/min)	Wire extension (mm)	Gas flow rate (L/min)
Fillet butt welding	1.6	0.8,0.9	60~80	16~17	40~50	10	10	
	2.3	0.8,0.9	80~100	19~20	40~55	10	10~15	
	3.2	1.0,1.2	120~160	20~22	35~45	10~15	10~15	
	4.5	1.0,1.2	150~180	21~23	30~40	10~15	20~25	

		Plate thickness (mm)	Wire diameter (mm)	Welding gun vertical angle(°)	Current (A)	Voltage (V)	Welding speed(cm/min)	Wire extension (mm)	Gas flow rate (L/min)
Horizontal fillet butt welding T joint	Low welding speed	1.0	0.8,0.9	45 <sup>0</sup>	70~80	17~18	50~60	10	10~15
		1.2	0.9,1.0	45 <sup>0</sup>	85~90	18~19	50~60	10	10~15
		1.6	1.0,1.2	45 <sup>0</sup>	100~110	19~20	50~60	10	10~15
		2	1.0,1.2	45 <sup>0</sup>	115~125	19~20	50~60	10	10~15
		2.3	1.0,1.2	45 <sup>0</sup>	130~140	20~21	50~60	10	10~15
		3.2	1.0,1.2	45 <sup>0</sup>	150~170	21~22	45~50	15	15~20
		4.5	1.0,1.2	45 <sup>0</sup>	140~200	22~24	45~50	15	15~20
		6	1.2	45 <sup>0</sup>	230~260	24~27	45~50	20	15~20
		8.9	1.2,1.6	50 <sup>0</sup>	270~380	29~35	45~50	25	20~25
	12	1.2,1.6	50 <sup>0</sup>	400	32~36	35~40	25	20~25	
	High welding speed	1.0	0.8,0.9	45 <sup>0</sup>	140	19~20	160	10	15
		1.2	0.8,0.9	45 <sup>0</sup>	130~150	19~20	120	10	15
		1.6	1.0,1.2	45 <sup>0</sup>	180	22~23	120	10	15~20
		2	1.2	45 <sup>0</sup>	210	24	120	15	20
		2.3	1.2	45 <sup>0</sup>	230	25	110	20	25
		3.2	1.2	45 <sup>0</sup>	270	27	110	20	25
		4.5	1.2	50 <sup>0</sup>	290	30	80	20	25
		6	1.2	50 <sup>0</sup>	310	33	70	25	25

		Plate thickness (mm)	Wire diameter (mm)	Welding gun vertical angle(°)	Current (A)	Voltage (V)	Welding speed (cm/min)	Wire extension (mm)	Gas flow rate (L/min)
Horizontal fillet welding joint	Low welding speed	0.8	0.8,0.9	10 <sup>0</sup>	60~70	16~17	40~45	10	10~15
		1.2	0.8,0.9	30 <sup>0</sup>	80~90	18~19	45~50	10	10~15
		1.6	0.8,0.9	30 <sup>0</sup>	90~100	19~20	45~50	10	10~15
		2.3	0.8,0.9	47 <sup>0</sup>	100~130	20~21	45~50	10	10~15
			1.0,1.2	47 <sup>0</sup>	120~150	20~21	45~50	10	10~15
		3.2	1.0,1.2	47 <sup>0</sup>	150~180	20~22	35~45	10~15	20~25
		4.5	1.2	47 <sup>0</sup>	200~250	24~26	45~50	10~15	20~25
	High welding speed	2.3~3.2	1.2	47 <sup>0</sup>	220	24	150	15	15
				47 <sup>0</sup>	300	26	250	15	15

# Appendix II Circuit diagram

## ● MIG 250GW

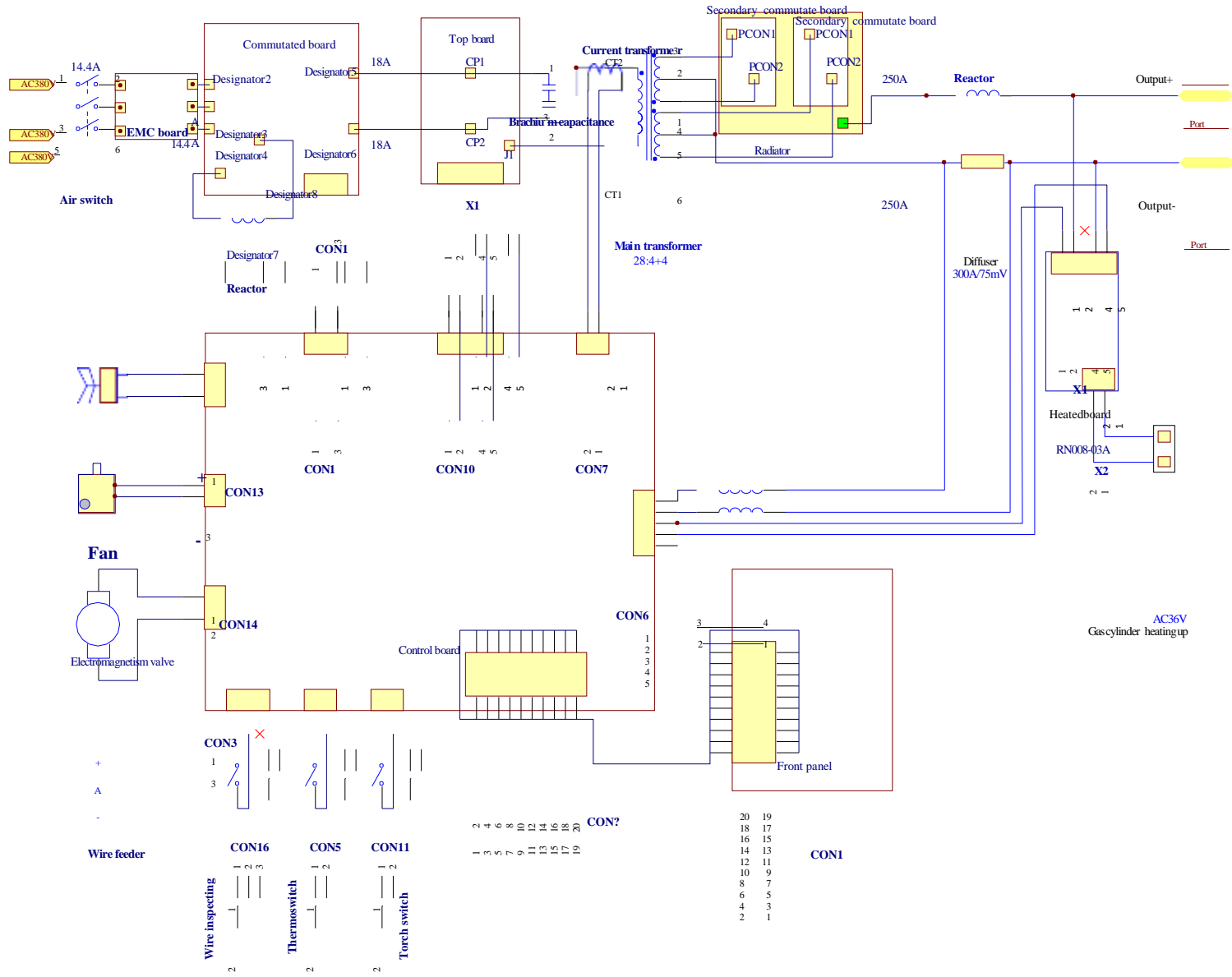

# Appendix III Component and list

- MIG 250GW

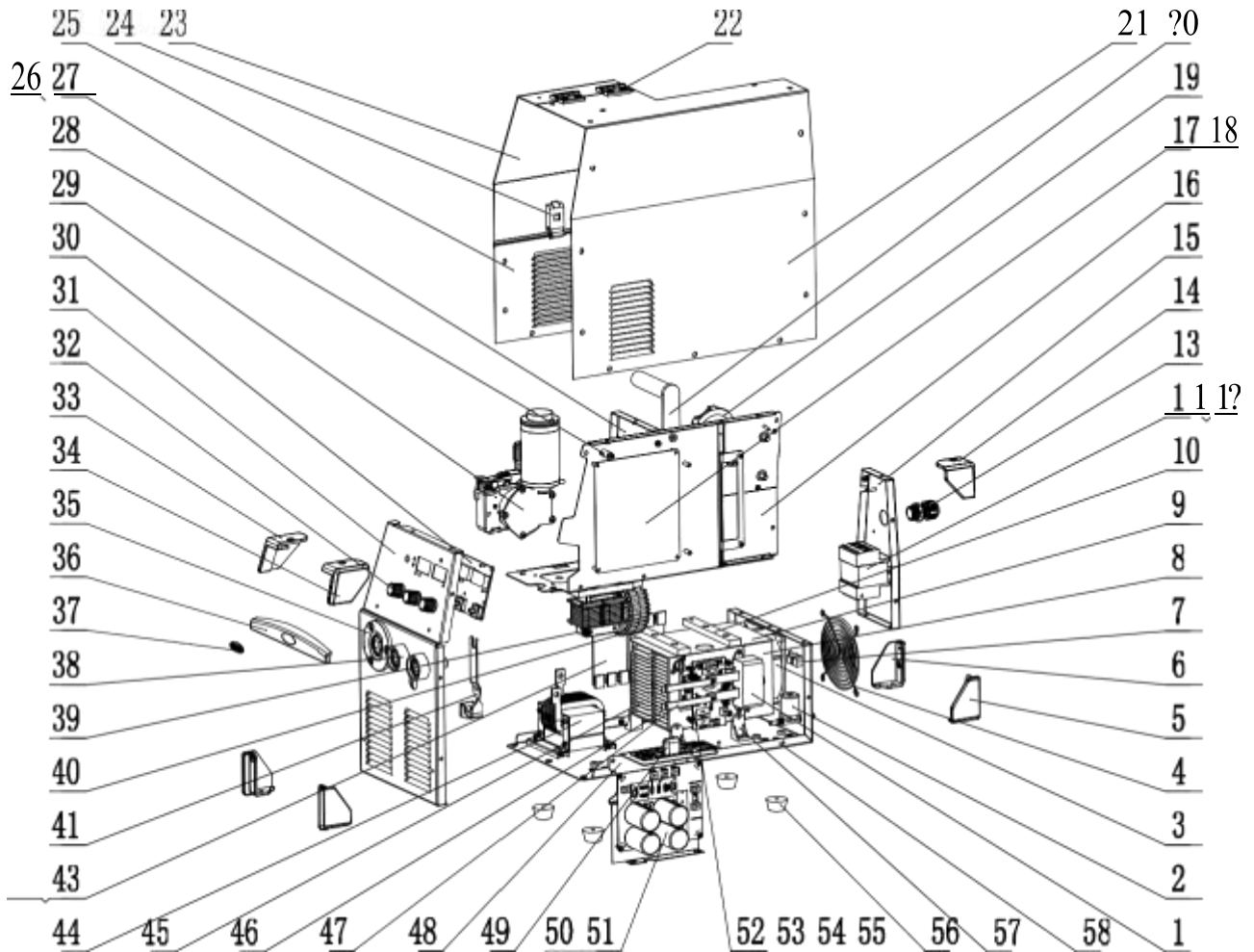

## Components list

NO.	Item	Quantity	NO.	Item	Quantity
1	Polyester capacitor	1	30	control board of front panel	1
2	Electromagnetism valve /solenoid valve	1	31	front panel	1
3	fan	1	32	knob	3
4	fan net	1	33	Front top protection angle of right side	1
5	back bottom protection angle of right side	2	34	Front top protection angle of left side	1
6	back bottom protection angle of left side	2	35	central switch socket	1
7	socket	1	36	Protection angle of front panel	1
8	side windshield board	2	37	epoxy sticker	1
9	Dust plate	2	38	quick socket	2
10	connector of heat sink	2	39	diffuser	1
11	air switch	1	40	Main transformer	1
12	Angle support	1	41	output connector	1
13	Self-locking cable ties	1	42	secondary commutate board	2
14	back top protection angle of right side	1	43	tableting	4
15	back panel	1	44	output reactor	1
16	clapboard	1	45	radiator (left)	1
17	control board	1	46	radiator (right)	1
18	control insulating board	1	47	commutate connector	2
19	wire roller	1	48	Support of commutated board	1
20	Handle stem	1	49	heat absorption plate	1
21	Right cover of machine	1	50	primary commutate board	1
22	hinge	2	51	primary commutate board with insulation	1
23	cover of machine	1	52	inverting board	1
24	Push lock	1	53	insulation tube	2
25	left cover of machine	1	54	tableting	2
26	clapboard	1	55	thermal buffer aluminium sheet	2
27	insulation ferrule	1	56	plastic foot	4
28	wire inspection switch	1	57	radiator support	4
29	wire feeder	1	58	bottom of machine	1