

NBC 350GF

WELDING MACHINE



USER MANUAL

Preface

This manual includes hardware description and operation introduction of the equipment. For your and other people's safety, please read the manual carefully.

Pay attention

Pay attention to the words after the signs below.

Sign	Description
 DANGER	The words after this sign means there is great potential danger, which may cause major accident, damage or even death, if it is not followed.
 WARNING	The words after this sign means there is some potential danger, which may cause hurt or property lose, if it is not followed.
 ATTENTION	The words after this sign means there is potential risk, which may cause equipment fault or break, if it is not followed.

Version

Version YF-TAE-0076, A0, Released on 12th, Oct., 2016.

The contents of this manual are updated irregularity for updating of product. The manual is only used as operation guide, except for other promises. No warranties of any kind, either express or implied are made in relation to the description, information or suggestion or any other contents of the manual.



The images shown here are indicative only. If there is inconsistency between the image and the actual product, the actual product shall govern.

CONTENTS

1. CONTENTS.....	3
2. SAFETY WARNING	4
3. MACHINE DESCRIPTION	9
4. TECHNICAL PARAMETERS TABLE	10
5. INSTALLATION INSTRUCTION.....	12
6. PANEL FUNCTION INSTRUCTION	14
7. WELDING PARAMETER RECOMMENDATION	16
8. CIRCUIT DIAGRAM.....	18
9. NOTES OR PREVENTIVE MEASURES	19
10. QUESTIONS TO BE RUN INTO DURING WELDING.....	20
11. DAILY CHECKING	22
12. EARLIER CHECKING DIAGRAM FOR THE ABNORMAL.....	24
13. REGULAR MAINTENANCE	26
14. TROUBLESHOOTING AND FAULT FINDING.....	27

SAFETY WARNING

- Please read this manual carefully before using it.
- The safety notes listed in this manual is to ensure correct use of the machine and to keep you and other people from being hurt.
- The machine is safety considered designed, please refer to the safety warning listed in the manual when using it in case of bad accidents.
- Wrong use of the machine will cause different extent of hurt as follows, and there will be warning sign and description for remind.

Warning sign	Description	Meaning
	High-danger	“High-danger” means there is possibility of severe dangerous, and may cause dead if not avoid. This sign is used in extreme case, which is normally related to body dangerous neither than property loss.
	Danger	“Danger” means there is possibility of dangerous situation, and may cause badly hurt if not avoid. It can also refer to property loss.
	Notes	This means it may cause body hurt if not avoid. Please refer to the related description when this sign occurred.



Danger! Please follow the rules below in case of bad accidents:

1. Do not use the machine in none-welding areas.
2. The machine is safety considered designed, please do read the warning notes carefully in case of dead or other bad accidents.
3. Follow related regulations for the construction of the input drive force, selection of the setup place, usage of the high-pressure gas, storage and configuration, safe-keeping of the workpiece after welding and management of the offal etc.
4. No entry of unrelated person to the welding area.
5. People using heart pacemaker cannot get close to the welding machine and area without the doctor's permit. The magnetism caused when connecting the machine will cause influence to the pacemaker.
6. Ask profession person to install, check and maintain the machine.
7. Please correctly understand the contents of this manual to ensure safety, and ask those

professional people with safety knowledge and technique to operate the machine.



Danger! Please follow the rules below in case of electric shock:



※ Any contact of electric parts may cause fatal electric shock or burnt.

1. Don't touch any electric parts.
2. Ask professional person to connect the machine and workpiece to the ground.
3. Cut off the power box before the installation or checking, and restart after 5 minutes. For the capacitance is chargeable, please ensure it has no voltage before restart even if the power source is cut off.
4. Do not use cable without enough section or with worn-out cover or broken conductor.
5. Do ensure insulation at the cable joint parts.
6. Do not use the machine when the housing is off.
7. Do not use broken or wet insulation gloves.
8. Use safety net when work at high position.
9. Check and maintain regularly, don't use it until the broken parts are fixed well.
10. Cut off all the input power when not use.
11. Follow the national or local related standard and regulations when using the AC/DC machine at narrow or high position.



Danger! Please use preventive measures to avoid gas and fumes.



※ Gas and fumes are harmful to health.

※ It may cause choke when operate in narrow space.

1. In case of accidents like gas poisoning or choke, please use suggested exhaust equipment and breathe preventive facilities.
2. In case of hurt and poisoning by gas and other powder, please use suggested part exhaust equipment and breathe preventive facilities.
3. When operated on trunks, boilers, cabins etc., the CO₂ and argon gas will stay in the bottom. Please replace gas sufficiently and use gas respire facilities in case of oxygen shortage.
4. Please accept the supervisor's check when operate in narrow space, and ensure enough gas supply and use breathe preventive facilities.
5. Do not weld in degrease, washing and spray space.
6. Use breathe preventive facilities as it will cause poisonous dust and gas when weld shielded steel.



Danger! Please follow the below notes to avoid accidents like fire and explode:



- * Spark and hot workpiece can cause fire.
- * It may cause fire if the cable is not connected well or when the current circuit of the steel or other workpiece are not connected completely.
- * Do not weld on the case of tinder stuff, or it may cause explode.
- * Do not weld airtight containers such as slot, pipe etc., or may break.

1. Do not put tinder stuff in welding area.
2. Do not weld around tinder gas.
3. Do not put heat workpiece near the tinder stuff.
4. When weld the dooryard, ground and wall, do move away the tinder stuff around.
5. The cable joint place should be insulated.
6. The cable joint of the workpiece should be close enough to the welding place.
7. Do not weld those facilities with gas pipe or airtight slot.
8. Put fire extinguisher around the welding area in case of fire.



Notes! Please wear protective appliance to avoid arc, spark, residue and noise.



Arc ray can cause eye inflammation or skin burnt.

- * Spark and residue will burn your eyes and skin.

1. When welding or supervise welding, please use preventive facilities with enough shielding.
2. Please wear preventive glasses.
3. Please wear preventive facilities such as leather gloves, coat, foot-safeguard and apron.
4. Set preventive shield screen around the welding area to protect other people from harmful arc rays.



Notes! Please follow the below notes to avoid gas cylinder toppling over or broken.



* Toppling over of the gas cylinder will cause body hurt.

* Wrong use of the gas cylinder will lead to high-pressure gas eruption and cause human hurt.

1. Use the gas cylinder correctly.
2. Use the equipped or recommended gas adjustment.
3. Read the manual of the gas adjustment carefully before using it, and pay attention to the safety notes.
4. Fix the gas cylinder with appropriate holder and other relative parts.
5. Do not put the cylinder under high temperature and sunshine.
6. Do not put your face close to the gas cylinder exit when opening it.

7. Put on the gas shield when not use.
8. Do not put the torch on the gas cylinder or touch the electrode.



Notes! Any touch of the switch part will cause injury, please pay attention to the below notes:



*** Do not put fingers, hair, clothes etc. near to the moving parts such as the fan.**

1. Do not use the machine when the housing is off.
2. Ask professional person to install, operate, check and maintain the machine.
3. Do not put fingers, hair, clothes etc. near to the switch parts such as the fan.



Notes! Follow the below note as the wire end may cause body hurt:



*** The wire shoot out from the torch can stab eyes, face and other naked parts.**

- 1 Before feeding the wire, do not look into the electric conduction hole, or the wire shooted out may stab your eyes and face.
- 2When feeding the wire manually or press the torch, do not put the torch end near to your eyes, face and other naked parts.



Notes! Follow the below notes to ensure better work efficiency and power source:



*** No person under of in front of the machine when swing in case of injury!**

1. Precautions against toppling over.
2. Warning against the use of welding power source for pipe thawing.
3. Lift the power source from two sides when use the up-down forklift truck in case of toppling over. 4 . When using the crane for lift, tie the rope to the ears with an angle no more than $\phi 15$ to the vertical direction.
5. If the machine is equipped with gas cylinder and wire feeder, download them from the power source and ensure the horizontal of the machine. Do fix the gas cylinder with gallus or chain when moving it in case of body hurt.
6. Ensure fastness and insulation when using the swing ring to lift the wire feeder in welding.
7. If the machine is equipped with gallus or handles, they are only for hands not for crane, fork-lift truck or other swing equipments.



Notes for electromagnetism disturb:

1. It may need extra preventive measures when the power is used in some partial space.
2. Before the installation, please estimate the potential electromagnetism problems of the environment as follows:
 - a) Upper and down parts of the welding equipments and other nearby power cable, control cable, signal cable and phone cable.
 - b) Wireless electric as well as TV radiation and reception equipment.
 - c) Computer and other control equipments.
 - d) Safety-recognition equipment etc. Eg: supervise of industrial equipments.
 - e) Health conditions of the people around. Eg: use of the heart pacemaker and audiphone.
 - f) Equipments for adjustment and measurement.
 - g) Anti-disturb capability of other used equipments .Users should ensure these equipments and the environment are compatible, and this may need extra preventive measures.
 - h) Practical state of the welding and other activities.
3. Users should follow the below notes to decrease radiation disturb:
 - a) Connect the welding equipments to the power supply lines.
 - b) Maintain the welding equipments regularly.
 - c) The cable should be short enough to be close to each other and near to the ground.
 - d) Ensure the safety of all the metal parts and other parts nearby.
 - e) The workpiece should be well connected to the ground.
 - f) Shield or protect the other cable and equipments to decrease the influence of disturb. The welding equipments can be fully shielded under special conditions.
4. Users are responsible for the disturb problems caused by welding.

MACHINE DESCRIPTION

MIG CO₂ gas shielded welding machines of our company are inverter welding machines manufactured by our company applying most advanced inversion technology in the world.

Their principle is to commutate the power frequency of 50Hz/60Hz into direct current, and then utilize the high-power device IGBT to invert it into high frequency (15 KHz/16KHz), then perform voltage-drop and commutate, and output high-power D.C power supply via Pulse Width Modulation (PWM). Since the switch power inversion technology is adopted, the weight and volume of the welding machine is brought down greatly with a conversion efficiency increase of more than 30%. Characteristic: stable wire feed rate, little splatter, portable, energy-saving, low electromagnetic noise.

The CO₂ gas shielded welding machine of our company is equipped with unique electronic reactor circuit, precisely controlling the short-circuiting transfer and mixed transfer of welding, producing excellent welding characteristic. Compared with silicon controlled welding machine and welder with taps, our products have the following merits: stable wire feed rate, portable, energy-saving, electromagnetic noise free. Besides, our products have merits such as electric network fluctuation self-compensation function, little splatter, good arc starting, deep welding pool, high duty cycle etc. This equipment can be applicable in large-scale plants such as shipyards, steel structure plants etc. featuring high efficiency and energy-saving.

The CO₂ gas shielded welding machine of our company has function of ending arc On/Off. Arc starting current and ending arc current can be adjusted separately, being very applicable for automatic welding. This machine is most suitable for the welding of mild steel, alloy steel and stainless steel.

Thank you for choosing our products. Please feel free to propose your valuable suggestions; we will make efforts to perfect our products and service.



WARNING !

The machine is mainly used in industry. It will produce radio wave, so the worker should make fully preparation for protection.

TECHNICAL PARAMETERS TABLE

Model Parameters	MIG 350GF	
Power voltage (V)	3 phase AC380V±15%	3 phase AC415V±15%
Frequency (Hz)	50/60	
No-load voltage(V)	61	66
Rated input current (A)	24 (MIG) 25.8(MMA)	22 (MIG) 23.6(MMA)
Output current adjust(A)	60 - 350 (MIG) 40 - 350 (MMA)	
Output voltage (V)	17 - 31.5(MIG) 21.6 - 34(MMA)	
Duty cycle (%)	35 (MIG) 30 (MMA)	
Power factor	0.93	
Efficiency (%)	85	
Type of wire feeder	Separated	
No-load loss(W)	190	
Wire feed speed (m/min)	3-15	
Post flow time (s)	1	
Welding-wire diameter (mm)	0.8/1.0/1.2	
Insulation grade	F	
Housing protection grade	IP21	
Welding thickness (mm)	More than 0.8	
Weight (kg)	30	
Overall dimension (mm)	526*272*468	

INSTALLATION INSTRUCTION

The welding equipment is equipped with power voltage compensation device. It keeps the machine work normally when power voltage fluctuating $\pm 15\%$ of rated voltage.

When using long cable, in order to reduce voltage drop, big section cable is suggested. If the cable is too long, it will affect the performance of arcing and other system function, it is suggested to use the recommend length.

1. Make sure the intake of the machine is not covered or blocked to avoid the malfunction of the cooling system.
2. Use ground cable whose section no less than 6mm^2 to connect the housing and earth. The method is to connect the grounded interface in the back to the earth device, or make sure the earth end of power interface has been reliably and independently grounded. Both ways can be used together for better security.
 - 1) Connect the main circuit cable of the wire feeder to the corresponding output end of the machine, and fasten with bolts.
 - 2) Connect the plug of the control circuit 6-core cable of the wire feeder to the corresponding interface of the machine and lock.
 - 3) Connect the plug of earth wire to the corresponding output end of the machine, and fasten with bolts.
 - 4) Install the CO_2 gas meter on the gas cylinder; connect the trachea of the wire feeder to the CO_2 gas meter tightly.
 - 5) Plug the welding gun to the welding gun output socket of the wire feeder and rotate 45° clockwise. Tighten the welding gun fastening screws with in turn spanner so as that the welding gun contacts with the wire feeder output socket reliably. Connect the controller plug and the gas connection to the wire feeder.
 - 6) Install the wire reel loaded with welding wire on the shaft bracket of the wire feeder, select different wire feeding groove according to the welding wire diameter.
 - 7) Loosen the pressure arm, feed the welding wire into wire feeding pipe through gadget wheel and groove. Press the pressure arm so that the wire pressing wheel presses the welding wire tightly to prevent the welding wire from sliding. Do not push the pressure arm too hard; prevent the welding wire from deformation and interfering with wire feeding. The welding wire roll rotates clockwise to loosen the welding wire. In order to prevent the leading end of wire reel from loosening, it is generally fixed to the fixing hole of the wire reel. Cut off this part of welding wire to prevent the winding welding wire from getting struck during normal operation.

Explanatory drawing for Installation (MIG)

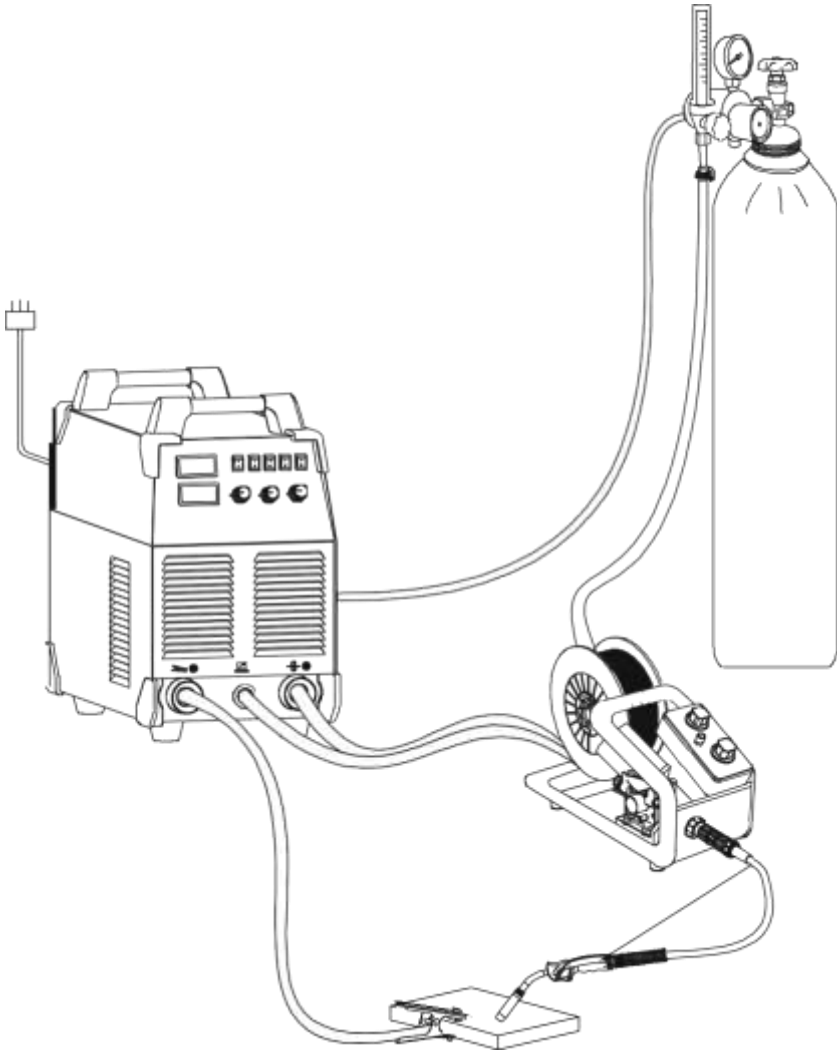

Explanatory drawing for Installation (MMA)

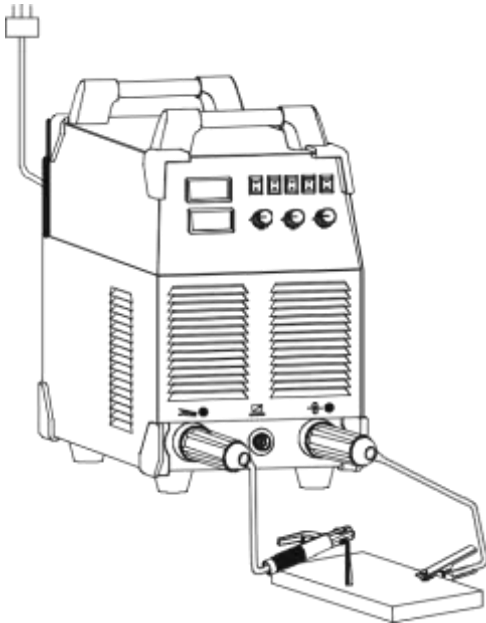

PANEL FUNCTION INSTRUCTION

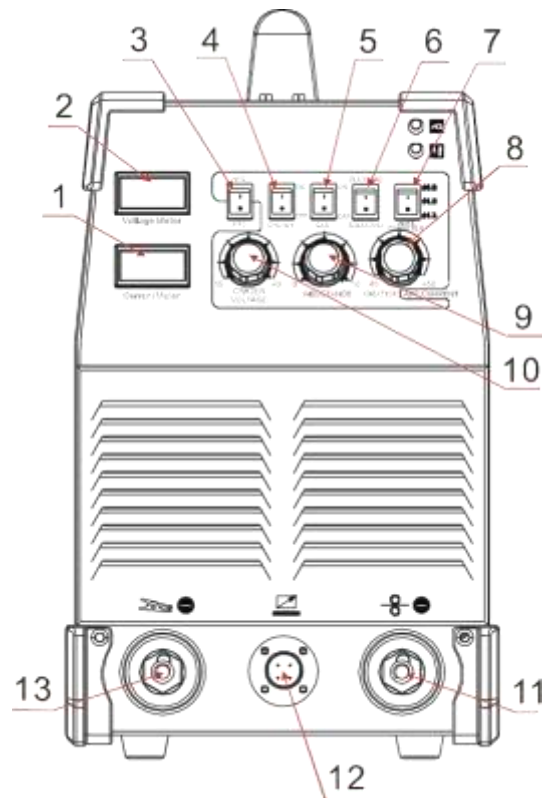

1	Current meter
2	Voltage meter
3	MIG/MMA changeover button
4	Crater change over button
5	Gas examining button
6	Solid/ flux-cored electrode change over button
7	Wire diameter selection button
8	Current adjustment knob
9	Inductance adjusting knob
10	Welding voltage adjustment knob
11	Positive output terminal Arc trait adjustment knob
12	Remove control output terminal
13	Negative output terminal

The images shown here are indicative only. The actual product may differ.

1. Change-over switch

- 1) Gas examining/welding change-over switch: When this switch is in the gas examining position, the gas supply of the welding machine is examined. When this switch is in the welding position, the welding machine is in the normal welding state.
- 2) Welding diameter change-over switch: When welding wires of different diameter are used, the switch shall be in the corresponding position correctly.

2. Adjusting knob

- 1) Welding voltage adjustment knob. 2
-) Welding current adjustment knob.
- 3) Inductance adjustment knob. Set the softness and hardness level of the electric arc to achieve the best welding performance. When the current is small, the electric arc shall be hard to reduce arc interruption. When large current, the electric arc shall be soft so as to reduce splatter.

3. Notice

The machine has the function of limited current, when the over-current, it would react, prevent the machine was damaged from over-current. So, you must select recommendatory Welding diameter and reasonable range of welding current.

WELDING PARAMETER RECOMMENDATION

The values listed in the following table are the general specification values under standard condition.

		Plate thickness (mm)	Wire diameter (mm)	Interval (mm)	Current (A)	Voltage (V)	Welding speed (cm/min)	Wire extension (mm)	Gas flow rate (L/min)	
I Square butt welding	Low welding speed	0.8	0.8,0.9	0	60~70	16~16.5	50~60	10	10	
		1.0	0.8,0.9	0	75~85	17~17.5	50~60	10	10~15	
		1.2	0.8,0.9	0	80~90	16~16.5	50~60	10	10~15	
		1.6	0.8,0.9	0	95~105	17~18	45~50	10	10~15	
		2.0	1.0,1.2	0~0.5	110~120	18~19	45~50	10	10~15	
		2.3	1.0,1.2	0.5~1.0	120~130	19~19.5	45~50	10	10~15	
		3.2	1.0,1.2	1.0~1.2	140~150	20~21	45~50	10~15	10~15	
		4.5	1.0,1.2	1.0~1.5	160~180	22~23	45~50	15	15	
			1.2	1.2~1.6	220~260	24~26	45~50	15	15~20	
			1.2	1.2~1.6	220~260	24~26	45~50	15	15~20	
			1.2	1.2~1.6	300~340	32~34	45~50	15	15~20	
			1.2	1.2~1.6	300~340	32~34	45~50	15	15~20	
		High welding speed	0.8	0.8,0.9	0	100	17	130	10	15
			1.0	0.8,0.9	0	110	17.5	130	10	15
1.2	0.8,0.9		0	120	18.5	130	10	15		
1.6	1.0,1.2		0	180	19.5	130	10	15		
2.0	1.0,1.2		0	200	21	100	15	15		
2.3	1.0,1.2		0	220	23	120	15	20		
3.2	1.2		0	260	26	120	15	20		

		Plate thickness (mm)	Wire diameter (mm)	Current (A)	Voltage (V)	Welding speed (cm/min)	Wire extension (mm)	Gas flow rate (L/min)
Fillet butt welding	1.6	0.8,0.9	60~80	16~17	40~50	10	10	
	2.3	0.8,0.9	80~100	19~20	40~55	10	10~15	
	3.2	1.0,1.2	120~160	20~22	35~45	10~15	10~15	
	4.5	1.0,1.2	150~180	21~23	30~40	10~15	20~25	

		Plate thickness (mm)	Wire diameter (mm)	Welding gun vertical angle(°)	Current (A)	Voltage (V)	Welding speed (cm/min)	Wire extension (mm)	Gas flow rate (L/min)
Horizontal fillet butt welding T joint	Low welding speed	1.0	0.8,0.9	45°	70~80	17~18	50~60	10	10~15
		1.2	0.9,1.0	45°	85~90	18~19	50~60	10	10~15
		1.6	1.0,1.2	45°	100~110	19~20	50~60	10	10~15
		2	1.0,1.2	45°	115~125	19~20	50~60	10	10~15
		2.3	1.0,1.2	45°	130~140	20~21	50~60	10	10~15
		3.2	1.0,1.2	45°	150~170	21~22	45~50	15	15~20
		4.5	1.0,1.2	45°	140~200	22~24	45~50	15	15~20
		6	1.2	45°	230~260	24~27	45~50	20	15~20
		8.9	1.2,1.6	50°	270~380	29~35	45~50	25	20~25
		12	1.2,1.6	50°	400	32~36	35~40	25	20~25
	High welding speed	1.0	0.8,0.9	45°	140	19~20	160	10	15
		1.2	0.8,0.9	45°	130~150	19~20	120	10	15
		1.6	1.0,1.2	45°	180	22~23	120	10	15~20
		2	1.2	45°	210	24	120	15	20
		2.3	1.2	45°	230	25	110	20	25
		3.2	1.2	45°	270	27	110	20	25
		4.5	1.2	50°	290	30	80	20	25
		6	1.2	50°	310	33	70	25	25
	Horizontal fillet welding joint	Low welding speed	0.8	0.8,0.9	10°	60~70	16~17	40~45	10
1.2			0.8,0.9	30°	80~90	18~19	45~50	10	10~15
1.6			0.8,0.9	30°	90~100	19~20	45~50	10	10~15
2.3			0.8,0.9	47°	100~130	20~21	45~50	10	10~15
			1.0,1.2	47°	120~150	20~21	45~50	10	10~15
3.2			1.0,1.2	47°	150~180	20~22	35~45	10~15	20~25
4.5			1.2	47°	200~250	24~26	45~50	10~15	20~25
High welding speed		2.3~3.2	1.2	47°	220	24	150	15	15
			1.2	47°	300	26	250	15	15

CIRCUIT DIAGRAM

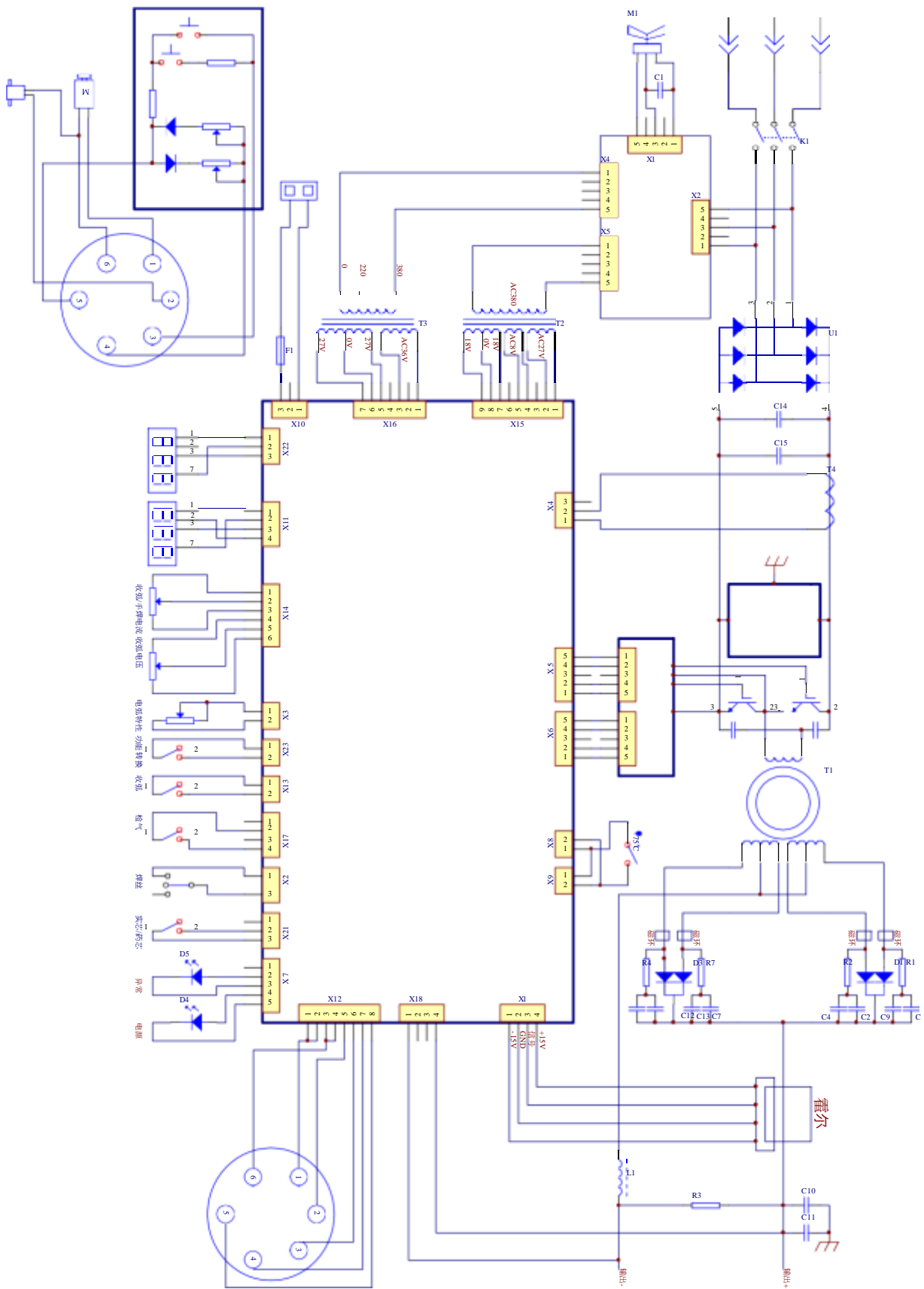

NOTES OR PREVENTIVE MEASURES



1. Environment

- 1) The machine can perform in environment where conditions are dry with a dampness level of max 90%.
- 2) Ambient temperature is between -10 to 40 degrees centigrade.
- 3) Avoid welding in sunshine or drippings. Do not let water enter the gas
- 4) Avoid welding in dust area or the environment with corrosive gas.
- 5) Avoid gas welding in the environment with strong airflow.

2. Safety norms

Our welding machine has installed protection circuit of over voltage, over current and over heat. When voltage, output current and temperature of machine are exceeding the rated standard, welding machine will stop working automatically. Because this will be damage to welding machine, user must pay attention to following.

- 1) **The working area is adequately ventilated** !
Our welding machine is powerful machine, when it is being operated, it generated high currents, and natural wind cannot satisfy with machine cool demands. So there is a fan inside the machine for its cooling demands. Make sure the intake is not in block or covered, there should be 0.3 meter distance from welding machine to objects of environment. User should make sure the working area is adequately ventilated. It is important for the performance and the longevity of the machine.
- 2) **Do not over load** !
The operator should remember to watch the max duty current (Response to the selected duty cycle) Welding current should not exceed max duty cycle current. Over-load current will damage and burn up the machine.
- 3) **No over voltage** !
Power voltage can be found in diagram of main technical data. Automatic compensation circuit of voltage will assure that welding current keeps is in allowable range. If power voltage is exceeding allowable range limits, it can damage the components of machine. The operator should understand this situation and take preventive measures.
- 4) There is a grounding screw behind welding machine, with a grounding marker on it. Before operation, welding crust must be grounded reliably with cable which section is over 6 square millimeters, in order to prevent from static electricity, and accidents because of electricity leaking.
- 5) If welding time is exceeding duty cycle limited, welding machine will stop working for protection. Because machine is overheated, temperature control switch is on "ON" position and the indicator light is red. In this situation, don't pull the plug, let the fan cool the machine. When the indicator light is off, and the temperature goes down to the standard range, it can weld again.

QUESTIONS TO BE RUN INTO DURING WELDING

The phenomenon listed below may be relevant to accessories used, welding material, surroundings and power supply. Please improve surroundings and avoid these situations.

A. Arc starting difficulty. Arc interruption happens easily:

- 1) Examine whether grounding wire clamp contacts with the work pieces well.
- 2) Examine whether each joint has improper contact.

B. The output current fails to reach rated value:

The deviation of power voltage from rated value may cause that the output current does not accord with adjusted value. When the power voltage is lower than rated value, the maximum output current may be lower than rated value.

C. The current can not keep stable during operation:

This situation may have connection to the following factors:

- 1) The voltage of electric power network changes;
- 2) Serious interference from electric power network or other electric facilities.

D. Gas pores in welds:

- 1) Examine whether the gas supply circuit has leakage.
- 2) Examine whether there is foreign substance such as oil, dirt, rust, paint etc. on the base metal.

MAINTENANCE



WARNING!

The power shall be cut off completely before all maintenance, overhaul works. Make sure to pull out power plug before opening the casing.

1. Remove dirt regularly with dry compressed air. If the welding machine is used in surroundings with heavy smoke and polluted air, carry out dust removal treatment at least once in a month.
2. The pressure of compressed air shall fall to required level to prevent damage to small components in the machine.
3. Examine inside electric joints and ensure perfect contact (Especially plugs and sockets). Fasten the loosing joints. In case of oxidation, remove oxide film with sand paper and connect again.
4. Prevent water from entering into the machine and prevent the machine from getting moist. If any, blow and dry. Measure the insulation with megohmmeter to make sure it is qualified for use.
5. If the welding machine is not used for a long time, pack the machine in original package and store in dry surroundings.
6. Every time the wire feeder operates for 300hours, grind the electrical carbon brush and clear up the armature commutator. Rinse speed reducer, apply 2# Molybdenum Disulfide lubricant to the turbine, whirlpool rod and bearing.

DAILY CHECKING

WELDING TORCH		
Position	Checking keys	Remarks
Nozzle	If installation fixed, the front distorted	Reason for air hole
	Attach splash or not	Reason for burning the torch (can use splash-proof material)
Electric hole	If installation fixed	Reason of torch screw thread damage
	Damage of its head and hole blocked or not	Reason of unstable arc and broken arc
Wire sending tube	Check the extended size of the pipe	Have to be changed when less than 6mm, when the extended part too small, the arc will be unstable
	Wire diameter and the tube inner diameter match or not	Reason of unstable arc, please use the suitable tube
	Partial winding and extended	Reason of poor wires sending and unstable arc, please change
	Block caused by dirt in the tube, and the remains of the wire plating lay	Reason of poor wire sending and unstable arc, (use kerosene to wipe or change new one)
	Wire sending tube broken	Pyrocondensation tube broken, change new tube
Gas bypass	Forget to insert or the hole blocked, or different factory component	May lead to vice (splash) because of poor gas shield, torch body get burned (arc in the torch), please handle

WIRE SENDING MACHINE		
Position	Checking keys	Remarks
Pressing arm	If put the arm to the suitable indicating level	Lead to unstable arc and wire sending
Wire lead tube	If powder or residue store up in the mouth of the tube	Clean the residue and check the reason and solve it
	Wire diameter and the tube inner diameter match or not	If not match, lead to unstable arc and residue
	If the tube mouth center matches the wire wheel slot center or not. (Eyeballing)	If unmatched, lead to unstable arc and residue
Wire wheel	Wire diameter matches the wheel's requirement If the wheel slot blocked	1. Lead to unstable arc and residue, and block wire tube 2. Change new one if necessary
Pressure wheel	Check the stability of its move, and wearing-out of pressed wire, the narrowing of its contact surface	Lead to unstable arc and wire sending

CABLE		
Position	Checking keys	Remarks
Torch cable	1. If torch cable over bended 2. If the metal connecting point of mobile plug loosen	1. Cause poor wire sending 2. Unstable arc if cable over bended
Output cable	1. Wearing-out of the cable insulated material 2. Cable connecting head naked (insulation damage), or loosen (the end of power supply, and cable of main material connecting point)	For life security and stable welding, adopt suitable method to check according to working place • Simple check daily • Careful and in-depth check on fixed period
Input cable	1. If the connection between the plug and the power socket is firm 2. If the power input end cable fixed 3. If the input cable is worn out and bares the conductor	
Earth cable	If the earth cable that connects the main part is broken and connects tightly	

EARLIER CHECKING DIAGRAM FOR THE ABNORMAL

Conclusion of an electric welding machine failure could not determine early even if abnormal phenomenon such as welding unable, arc unstable or bad welding effect occur.

The above-mentioned abnormal phenomenon may be caused by some reasons without any failure but the machine operates normally. For example: tight parts loosen, forgetting to switch on, wrong set up, cable broken and gas rubber pipe cracked, etc. Therefore, please test and inspect those factors before the machine to be delivered back the factory for overhauling is determined because a large number of troubles may be readily solved probably.

For this reason, an initial diagnosis list for general welding troubles is shown below. A trouble happened may be found in the column of "Abnormal items" on up-right of the list, please inspect and maintain for the corresponding items which have "○" mark in the column according to the following list respectively.

Earlier Checking Diagram for the Abnormal

Abnormal Items		No arch Arc Starting	No Gas out	No Wire Feeding	Bad Arc Ignition	Unstable Arc	Dirt on Edge of Weld Seam	Wire Stick to Parent material	Wire Stick to Conductive Tip	Blowhole Formed
Area and Item to be Inspected and Maintained										
Distribution Boxes (Input Protection Devices)	1. Turn on power supply or not? 2. Fuse burnt out 3. Connection joint loose	○	○	○	○	○	○			
Input Cable	1. Examine whether the cable is cut off. 2. Connection joint loose 3. Over heat	○			○	○	○			
Welding Power Operation	1. Turn on power supply or not? 2. Phase Lacking	○	○	○	○	○	○	○	○	
Gas Cylinder and Gas Regulator	1. Turn on gas supply 2. Residual Amount of Gas in the Cylinder 3. Set value for flow 4. Connection joint loose					○				○
Gas supply hose (the whole line from the high pressure cylinder to the weld gun)	1. Connection joint loose 2. Gas hose damaged									○

Earlier Checking Diagram for the Abnormal

Abnormal Items		No arch	No Gas out	No Wire Feeding	Bad Arc Ignition	Unstable Arc	Dirt on Edge of Weld Sea	Wire Stick to Parent material	Wire Stick to Conductive Tip	Blowhole Formed
Area and Item to be Inspected and Maintained										
Wire Feeding Device	1. Wire feeding wheel does not match with the diameter of wire in texturing tube 2. Crackle on wire feeding wheel, groove blocked up or defect 3. Too tight or loose of the handle 4. Wire powder accumulated on the inlet of SUS pipe			○	○	○	○		○	
Weld Gun and Cable	Weld gun cable rolled up or over curved Adaptability of conductive tip, wire feeding pipe and cable diameter Worn, blocked up or deformation, etc.				○	○	○		○	
Body of weld gun	1. Loose connection of conductive tip, nozzle and nozzle contactor 2. Contactor of weld gun body is not plunged in or tightened well						○			○
Power supply cable of weld gun as well as cable of switch control	1. Break off (bending fatigue) 2. Damaged by weight drop	○	○	○		○		○		
Surface Condition of Parent material and length that wire stretches out	1. Oil, dirty, rust and paint residues 2. Too long length of wire stretched out				○	○	○	○		○
Output Cable	1. Cross-section of cable that connects to parent material is not enough 2. Loose connection of (+) , (-) output cable 3. Bad electric conductivity of parent material				○	○	○			
Lengthened Cable	1. Cross-section of cable is not enough 2. It is rolled up or folded				○	○	○	○		
Work Condition for Welding	Welding current, voltage, angle of weld gun, welding rate and wire length stretched out should be confirmed once again				○	○	○	○	○	

REGULAR MAINTENANCE

For abnormal conditions that have been described in “Initial Diagnosis for an Abnormal Phenomenon” and “Abnormal Status Shown by Indicator Lamps and Relevant Treatment Countermeasures”, the reasons should be found out in accordance with the following sequence then the relevant treatment countermeasures should be determined.

Failure and Abnormity Examining

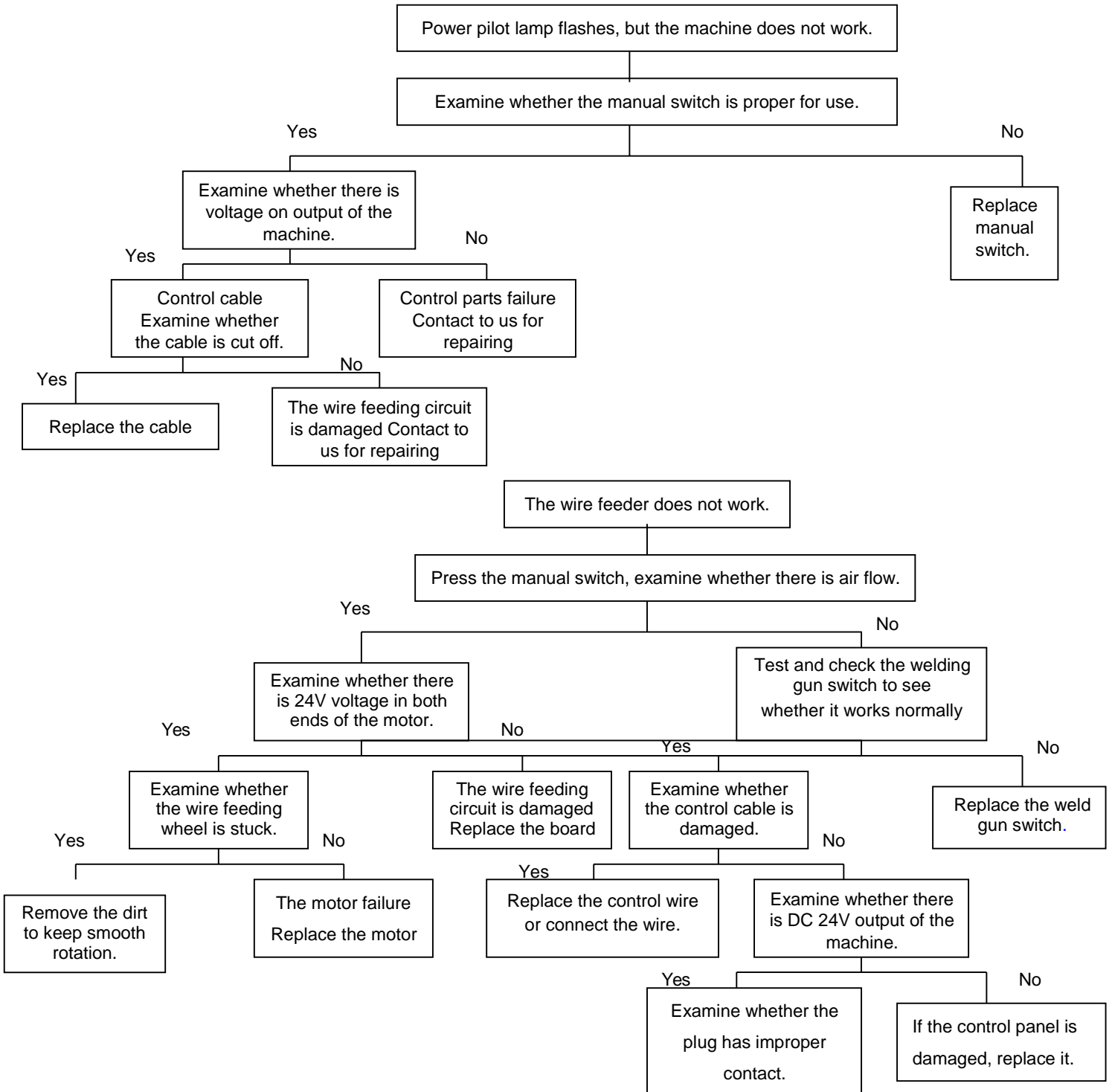

TROUBLESHOOTING AND FAULT FINDING



Notes: The following operations must be performed by qualified electricians with valid certifications. Before maintenance, please contact with us for professional suggestion.

Fault symptom and solution.

Fault symptom	Solution
The meter show nothing; Fan does not rotate; No welding output	<ol style="list-style-type: none">1. Confirm the power switch is off.2. Power supply available for input cable.3. Check if the three-phase rectifier bridge is damaged.4. There is malfunction occurs in the auxiliary power source on control board (contact to dealers).
The meter shows; Fan works normally; No welding output	<ol style="list-style-type: none">1. Check if all the sockets in the machine are connect well.2. There is open circuit or badness of connect at the joint of output terminal.3. The control cable on the torch is broken off or the switch is damaged.4. The control circuit is damaged.(contact to dealers)
the meter shows; Fan works normally; Abnormal indicator lights.	<ol style="list-style-type: none">1. It might be over current protection, please turn off the power switch; restart the machine after the abnormal indicator light winked.2. It might be over hot protection, please wait for about 2-3 minutes until the machine renew without turn off the power switch.3. It might be multifunction of inverter circuit.