

TIG 200CT

WELDING MACHINE



USER MANUAL

Preface

This manual includes hardware description and operation introduction of the equipment. For your and other people's safety, please read the manual carefully.

Pay attention

Pay attention to the words after the signs below.

Sign	Description
 DANGER	The words after this sign means there is great potential danger, which may cause major accident, damage or even death, if it is not followed.
 WARNING	The words after this sign means there is some potential danger, which may cause hurt or property lose, if it is not followed.
 ATTENTION	The words after this sign means there is potential risk, which may cause equipment fault or break, if it is not followed.

Version

Version YF-TAE-0113, A2. Released on 30th. Nov. 2018.

The contents of this manual are updated irregularity for updating of product. The manual is only used as operation guide, except for other promises. No warranties of any kind, either express or implied are made in relation to the description, information or suggestion or any other contents of the manual.

CONTENTS









1	Safety Warning	2
2	Product.....	6
	2.1 General.....	6
	2.2 Technical Data	7
3	Installation.....	9
4	Operation	12
	4.1 Front Panel Layout.....	12
	4.2 Operation Instruction.....	14
	4.3 Welding Environment and Safety	15
	4.4 Welding Problems and Resolution.....	16
5	Daily Maintenance and Checking.....	17
6	Trouble Shooting and Fault Finding	18
	Appendix I Circuit Diagram	20

1 Safety Warning

The safety notes listed in this manual is to ensure correct use of the machine and to keep you and other people from being hurt.

The design and manufacture of welding machine considers safety. Please refer to the safety warning listed in the manual to avoid accidents.

Different damage would be caused by wrong operation of the equipment as follows. Please read the user manual carefully to reduce such damage.

Sign	Description
	<ul style="list-style-type: none"> ◇ Any contact of electric parts may cause fatal electric shock or burnt.
	<ul style="list-style-type: none"> ◇ Gas and fumes are harmful to health. ◇ Operation in narrow space may cause choke.
	<ul style="list-style-type: none"> ◇ Spark and hot workpiece after welding may cause fire. ◇ Bad connected cable may cause fire. ◇ Incompletion connection of workpiece side circuit may cause fire. ◇ Never weld on the case of tinder stuff, or it may cause explode. ◇ Never weld airtight containers such as slot, pipe etc., or it may break.
	<ul style="list-style-type: none"> ◇ Arc ray may cause eye inflammation or skin burnt. ◇ Spark and residue will burn your eyes and skin.
	<ul style="list-style-type: none"> ◇ Toppling over of the gas cylinder will cause body hurt. ◇ Wrong use of the gas cylinder will lead to high-pressure gas eruption and cause human hurt.
	<ul style="list-style-type: none"> ◇ Never let fingers, hair, clothes or etc. near the moving parts such as the fan.
	<ul style="list-style-type: none"> ◇ The wire shoot out of the torch may stab eyes, face and other naked parts.
	<ul style="list-style-type: none"> ◇ The machine is portable, never lift it by any equipment.



DANGER

Please follow the rules below to avoid heavy accidents.

- Never use the equipment to do other things but welding.
- Follow related regulations for the construction of the input-driven power source, choice of place, usage of high-pressure gas, storage, configuration, safe-keeping of workpiece after welding and disposal of waste, etc.
- Nonessentials do not enter the welding area.
- People using heart pacemaker is not allowed to get close to the welding machine or area without doctor's permission. The magnetism created by energizing the welding machine can have a bad effect to the pacemaker.
- Install, operation, check and maintain the equipment by profession personnel.
- Understanding the contents of the user manual for safety.



DANGER

Please follow the rules below to avoid electric shock.

- Keep away from any electric parts.
- Earth the machine and workpiece by professional personnel.
- Cut off the power before installation or checking, and restart 5 minutes later. The capacitance is chargeable device. Please ensure it has no voltage before start again even if the power source is cut off.
- Do not use wire with inadequate section surface or damage insulation sleeve or even exposed conductor.
- Do ensure well isolation of wire connection.
- Never use the device when the enclosure is removed.
- Never use broken or wet insulation gloves.
- Use firenet when work at high position.
- Check and maintain regularly, don't use it until the broken parts are fixed well.
- Turn off the power when not in used.
- Follow the national or local related standard and regulations when using the AC welding machine at narrow or high position.



DANGER

Please follow the below notes to avoid fire and explode, etc.

- No combustibile in welding area.
- Keep off combustibile when welding.
- Keep hot workpiece after welding away from flammable gas.
- Do move away the combustibile around when weld the dooryard, ground and wall,.
- The wire connection of base metal should be as close to the welding place as possible.
- Never weld those facilities with gas pipe or airtight slot.
- Put fire extinguisher around the welding area to prevent fire.

 **WARNING** The gas and fumes are harmful to health, please wear protective device according to regulations.

- Wear exhaust equipment and breathe preventive facilities to prevent gas poisoning or choke.
- Use suggested part exhaust equipment and breathe preventive facilities to prevent hurt or poisoning by gas and other powder, please.
- To prevent oxygen-deficiency, air out the gas-filled room which is full of CO₂ and argon on the bottom, when operating on trunks, boilers, cabins, etc.
- Please accept the supervisor's inspection when operating in narrow space. Air the room and wear breathe preventive facilities.
- Never operate in degrease, washing or spray space.
- Using breathe preventive facilities when weld shielded steel for it will cause poisonous dust and gas.

 **WARNING** The arc, spark, residue and noise are harmful to health, please wear protective appliance.

- Eye protection against arc is recommended when welding or supervise welding.
- Please wear preventive spectacles.
- Welder's gloves, welder's goggles, long sleeve clothes, leather apron, and other standard protection equipments must be worn for welding operation.
- A screen to protect other people against the arc must be set in the welding place.

 **WARNING** Please follow the notes below to avoid gas cylinder toppling over or broken.

- Use the gas cylinder correctly.
- Use the equipped or recommended gaseous regulator.
- Read the manual of gaseous regulator carefully before using it, and pay attention to the safety notes.
- Fix the gas cylinder with appropriate holder and other relative parts.
- Never put the cylinder under high temperature or sunshine environment.
- Keep your face away from the gas cylinder exit when opening it.
- Put on the gas shield when it is not used.
- Never put the torch on the gas cylinder. The electrode can not meet the gas cylinder.

 **WARNING** Any touch of the switch part will cause injury, please note the following.

- Never use the machine when the enclosure is off.
- Install, operate, check and maintain the machine by professional person.
- Keep your fingers, hair, clothes etc. away from the switch parts such as the fan.



WARNING The wire end may deal damage, please note the following.

- Never look into the electric conduction hole when checking the wire feeding is normal or not, or the shooting wire may stab your eyes and face.
- Keep your eyes, face or other naked parts away from the end of torch when feeding the wire manually or pressing the switch.



ATTENTION For better work efficiency and power source maintenance, please note the following.

- Precautions against toppling over.
- Never use the welding equipment for pipe thawing.



ATTENTION Electromagnetic interference needing attention.

- It may need extra preventive measures when the equipment is used in particular location.
- Before the installation, please estimate the potential electromagnetism problems of the environment as follows.
 - a) Upper and lower parts of the welding equipments and other nearby power cable, control cable, signal cable and phone cable.
 - b) Wireless electric as well as TV radiation and reception equipment.
 - c) Computer and other control equipments.
 - d) Safety-recognition equipment etc. Such as supervise of industrial equipments.
 - e) Health of people around. Such as personnel using the heart pacemaker or audiphone.
 - f) Equipments for adjustment and measurement.
 - g) Anti-disturb capability of other used equipments .Users should ensure these equipments and the environment are compatible, which may need extra preventive measures.
 - h) Practical state of the welding and other activities.
- Users should observe the following dos and don'ts to decrease radiation interference.
 - a) Connect the welding equipments to the power supply lines.
 - b) Maintain the welding equipments regularly.
 - c) The cable should be short enough to be close to each other and the ground.
 - d) Ensure the safety of all the welding metal parts and other parts nearby.
 - e) The workpiece should be well earth.
 - f) Shield or protect the other cable and equipments to decrease the effects of disturbances. The welding equipments can be complete shielded in some special conditions.
- Users are responsible for interference due to welding.

2 Product

2.1 General

Welding machine is a rectifier adopting the most advanced inverter technology.

The development of welding equipment benefits from the appearance of the inverter power supply theory and components. Inverter arc welding power source utilizes high-power component MOSFET to transfer 50/60Hz frequency up to 100KHz, then reduce the voltage and commutate, and output high-power voltage via PWM technology. Because of the great reduce of the main transformer's weight and volume; the efficiency increases by 30%. The appearance of inverter welding equipment is considered to be a revolution for welding industry.

Welding power source can offer stronger, more concentrated and more stable arc. When stick and workpiece get short, its response will be quicker. It means that it is easier to design into welding machine with different dynamic characteristics, and it even can be adjusted for specialty to make arc softer or harder.

TIG welding machine is easy for arc initiation and has the functions of arc initiation current, arc stop current, welding current, basic value current, current ascending time, current descending time, gas delay time, continuous adjustment. What's more, pulse frequency and pulse duty can also be adjusted independently. It has the characteristics of automatic control of arc initiation, arc stop and stable arc, which make the best result for shape and inner quality of the welding surface. Its exclusive design is specially suitable for bicycle industry.

The machine can be for multi-use, and can weld stainless steel, carbon steel, copper and other color metal, and also can use for traditional electric welding.

Thanks for purchasing our products and looking forward to your precious advice, we will try our best to perfect our products and service.



The machine is mainly used in industrial fields. It will cause radio interference if used indoors. Please take through precaution measures.

2.2 Technical Data

Model	TIG 200CT
Parameters	
Power voltage (V)	single phase AC220V±15%
Frequency (Hz)	50/60
Rated input current (A)	26 (TIG) 31.2 (MMA)
Output current (A)	10~180 (TIG) 10~155 (MMA)
Rated working volt (V)	17.2 (TIG) 26.2 (MMA)
No-load volt (V)	U ₀ =58, U _r =16.5
Duty cycle (%)	30 (TIG) 40 (MMA)
Arcing way	HF
Efficiency (%)	80
Power factor	0.73
Insulation grade	F
Housing protection grade	IP21S
Weight (Kg)	6.5
Dimensions (L*W*H mm)	402*160*300

3 Installation

Equipment is equipped with power voltage compensation equipment. When power voltage fluctuates between $\pm 15\%$, of rated voltage, it still can work normally.

When use long cable, in order to prevent voltage form going down, bigger section cable is suggested. If cable is too long, it may affect the performance of the power system. So cables of configured length are suggested.

The Installation diagram of Gas-electricity system(TIG)

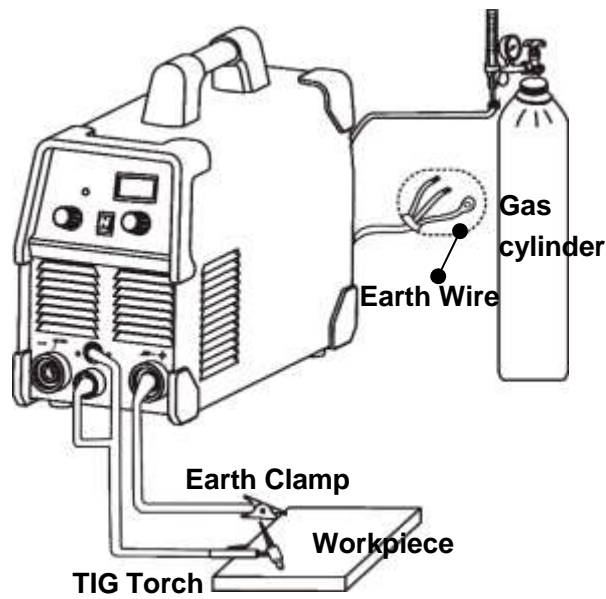

TIG 200CT

The Installation diagram of Gas-electricity separation(TIG)

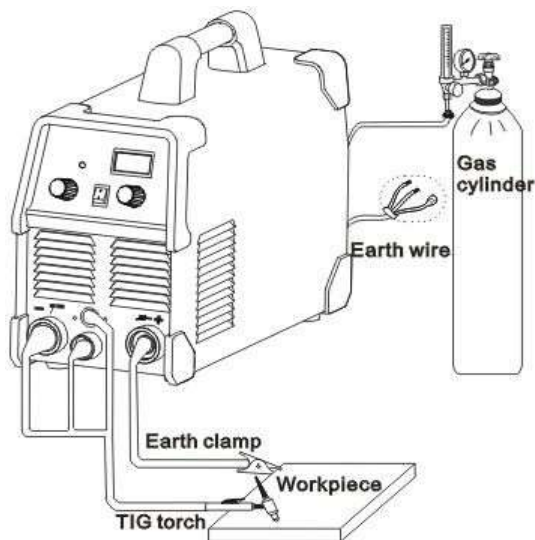

TIG 200CT

Installation steps (TIG)

- Make good connection of shielded gas source.

Gas supply passage includes cylinder, argon decompress flow meter and pipe. Connecting part of pipe should use hoop or other things to fasten, lest argon leaks out and air gets in.

- The machine of Gas-electricity system:

Connect the fast plug of the TIG torch to the gas and electricity output terminal at the front panel, and fasten it clockwise.

Connect the torch switch of the TIG torch to the joint at the front panel, and fasten the screw.

- The machine of Gas-electricity separation:

Connect the fast plug of the TIG torch to the socket of “-” terminal at the front panel, and fasten it clockwise.

Connect the gas joint of the TIG torch to the gas output terminal at the front panel, and fasten the screw.

Connect the torch switch of the TIG torch to the joint at the front panel, and fasten the screw.

- Connect the fast plug of the earth clamp to the socket of “+” terminal at the front panel, and fasten it clockwise.
- Clamp the earth clamp onto the workpiece.
- When the power supply is connected, the welding operation can be carried out.

NOTE: the ground wire in the power cable must be grounded.

Installation diagram of TIG 200CT (MMA)

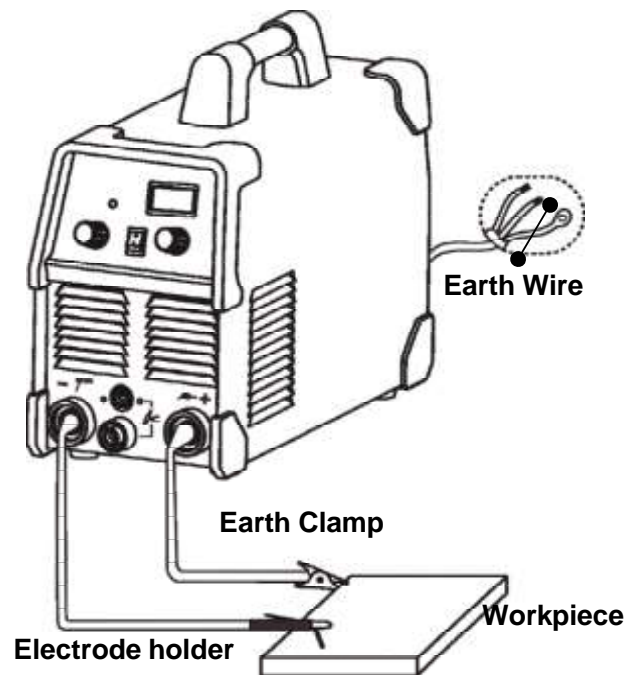

Installation steps of TIG 200CT (MMA)

- Connect the fast plug of the electrode holder to the socket of “-” terminal at the front panel, and fasten it clockwise.
- Connect the fast plug of the earth clamp to the socket of “+” terminal at the front panel, and fasten it clockwise.
- Clamp the earth clamp onto the workpiece.
- When the power supply is connected, the welding operation can be carried out.

NOTE: the ground wire in the power cable must be grounded.

4 Operation

4.1 Panel Layout

TIG 200CT

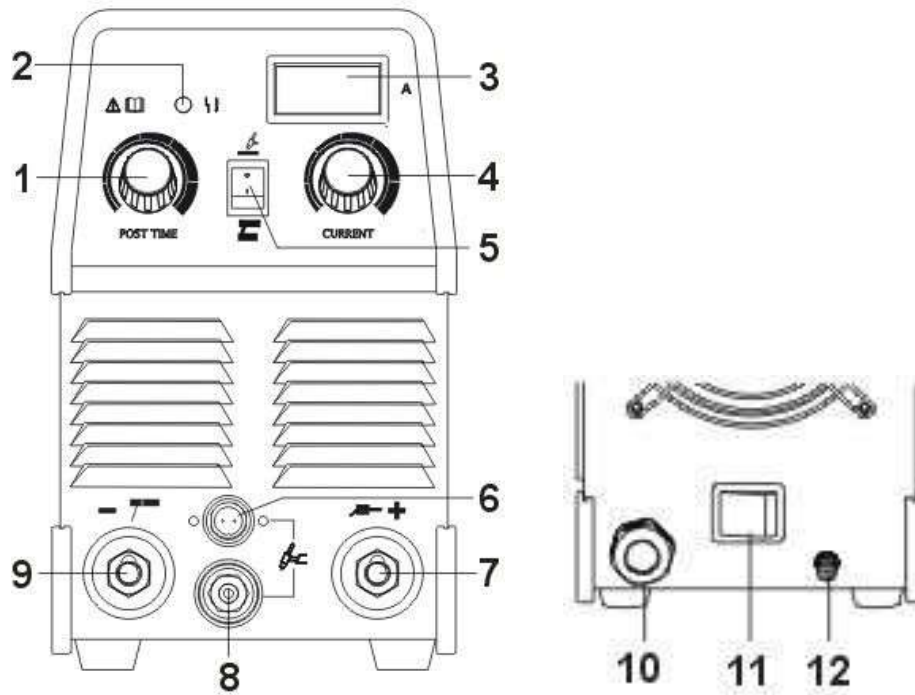

No.	Name	Description
1	Post time knob	Used to adjust the post gas time. After the welding is stopped, gas is sent out in the set time to ensure that the solder joint is protected before cooling.
2	Abnormal indicator	In the case of overheating or over current, the indicator will light on and the machine stop working.
3	Current meter	Display the welding parameter.
4	Welding current knob	Used to adjust the welding current.
5	TIG/MMA switch	Used to switch the TIG and MMA function
6	Torch switch socket	Connect to the torch switch
7	Output terminal (+)	The positive output terminal
8	Gas and electricity output terminal	Connect to the TIG torch
9	Output terminal (-)	The negative output terminal
10	Power supply cable	-
11	Power switch	-
12	Gas in terminal	Connect to the gas source
13	Gas output terminal	Connect to the TIG torch

Note. The image above is for reference only. If any difference with the real machine, please follow with the real machine.

4.2 Operation Instruction

● TIG Welding Description

- a) Turn on the power switch of front panel.
- b) Press the TIG/MMA switch to “TIG” position (TIG 200CT) .
- c) Turn on the argon switch, and set the gas pressure to rated value.
- d) Press the switch of torch, electromagnetic valve is started. You will hear the sound of electricity-releasing HF sparkle and at the same time, argon gets out the torch.

Note. If welding for the first time, before operating, please press the switch for a few seconds until all the air in the gas tube is removed. Then, welding could be started.

When stop welding and the electric arc stick out, keep the welding position for a while so that the weld spot could be protected before cooling down for delaying argon. The post time could be adjusted by turning the post time knob on the front panel.

- e) Set the welding current according to the thickness of work piece and process demand.
- f) Keep 2-4mm space between tungsten pole and work piece, press torch control switch, between electrode and work piece HF electricity is released; After arc initiation, HF sparkle disappears soon and can start to work.

● MMA Welding Description (TIG 200CT)

- a) Turn on the power switch on the front panel.
- b) Press the TIG/MMA switch to “MMA” position.
- c) Set the welding current according to work piece’s thickness, position, craftwork state.



It is forbidden to pull out or put in the cable or connector during the process of welding, which will threat life safety and damage the machine.

4.3 Welding Environment and Safety

- **Environment**

- a) The machine can perform in environment where conditions are dry with a dampness level of max 90%.
- b) Ambient temperature is between -10 to 40 degrees centigrade.
- c) Avoid welding in sunshine or drippings. Do not let water enter the gas
- d) Avoid welding in dust area or the environment with corrosive gas.
- e) Avoid gas welding in the environment with strong airflow.

- **Safety norms**

Our welding machine has installed protection circuit of over voltage, over current and over heat. When voltage, output current and temperature of machine are exceeding the rate standard, welding machine will stop working automatically. Because that will be damage to welding machine, user must pay attention to following.

- a) **The working area is adequately ventilated !**

Our welding machine is powerful machine, when it is being operated, it generated by high currents, and natural wind can't be satisfied with machine cool demands. So there is a fan in inter-machine to cool down machine. Make sure the intake is not in block or covered, it is 0.3 meter from welding machine to objects of environment. User should make sure the working area is adequately ventilated. It is important for the performance and the longevity of the machine.

- b) **Do not over load !**

The operator should remember to watch the max duty current (Response to the selected duty cycle).Keep welding current is not exceed max duty cycle current. Over-load current will damage and burn up machine.

- c) **No over voltage !**

Power voltage can be found in diagram of main technical data. Automatic compensation circuit of voltage will assure that welding current keeps in allowable range. If power voltage is exceeding allowable range limited, it is damaged to components of machine. The operator should understand this situation and take preventive measures.

If welding time is exceeded duty cycle limited, welding machine will stop working for protection. The machine is overheated, temperature control switch is on "ON" position and the indicator light is red. In this situation, you don't have to pull the plug, in order to let the fan cool the machine. When the indicator light is off, and the temperature goes down to the standard range, it can weld again.

4.4 Welding Problems and Resolution

Fittings, welding materials, environment factor, supply powers maybe have something to do with welding. User must try to improve welding environment.

- **Black welding spot.**

Welding spot is not prevented from oxidizing .User may check as following:

- a) Make sure the valve of argon cylinder is opened and its pressure is enough. Argon cylinder must be filled up to enough pressure again if pressure of cylinder is below 0.5Mpa .
- b) Check if the flow meter is opened and has enough flow .User can choose different flow according to welding current in order to save gas .But too small flow maybe cause black welding spot because preventive gas is too short to cover welding spot .We suggest that flow of argon must be kept min 5L/min.
- c) Check if torch is in block.
- d) If gas passage is not air-tight or gas is not pure can lower welding quality.
- e) If air is flowing powerfully in welding environment, that can lower welding quality.

- **Arc-striking is difficult and easy to pause.**

- a) Make sure quality of tungsten electrode is high.
- b) Grind end of the tungsten electrode to taper .If tungsten electrode is not grinded, that will be difficult to strike arc and cause unstable arc.

- **Output current not to rated value.**

When power voltage departs from the rated value, it will make the output current not matched with rated value; when voltage is lower than rated value, the max output may lower than rated value.

- **Current is not stabilizing when machine is being operated.**

It has something with factors as following.

- a) Electric wire net voltage has been changed.
- b) There is harmful interference from electric wire net or other equipment.

- **When use MMA welding, too much spatter**

- a) Maybe current is too big and stick's diameter is too small.
- b) Output terminal polarity connection is wrong, it should apply the opposite polarity at the normal technique, which means that the stick should be connected with the negative polarity of power source, and work piece should be connected with the positive polarity. So please change the polarity.

5 Daily Maintenance and Checking

- **Daily maintenance**

- a) Remove dust regularly with dry compressed air. If the welding machine is used in surroundings with heavy smoke and polluted air, it is necessary to remove dust at least one time one month.
- b) The pressure of compressed air shall fall to required level to prevent damage to small components in the machine.
- c) Examine inside electric joints and ensure perfect contact (Especially plugs and sockets). Fasten the loosing joints. In case of oxidation, remove oxide film with sand paper and connect again.
- d) Prevent water from entering into the machine and prevent the machine from getting moist. If any, blow and dry. Measure the insulation with megohmmeter to make sure it is qualified to use.
- e) If the welding machine is not used for a long time, pack the machine in original package and store in dry surroundings.



The power shall be cut off completely before all maintenance, repairing works. Make sure to pull out power plug before opening the case.

- **Notes before checking**



Aimless test and unprofessional repairing may make the problems worse and cause more defaults. When the power is on, the bare components may be dangerous with high voltage. Any direct or indirect touch may cause electric shock, even death.



Within the warranty period, if the users handle unprofessionally of the malfunctions by themselves without permission of manufactory, the free repair guaranteed by the distributors may not be effective.

6 Trouble Shooting and Fault Finding

Faults symptom	Solutions
Power indicator is not lit, fan does not work and no welding output	<ul style="list-style-type: none"> ➤ Power switch is damaged. ➤ Make sure the electric wire net connecting to input cable is working alright ➤ Make sure if input cable has broken circuit.
Power indicator is lit, fan does not work or revolve several circles and stopped, no welding output	<ul style="list-style-type: none"> ➤ Input cable is possibly connected to 380V power, which causes over voltage protection circuit is starting. Connect input cable to 220V power, and then restart the machine. ➤ Erratic 220V power supply (input cable is too thin and long) or input cable is connected to electricity network would start overload voltage protection circuit. Increase section of input cable or tighten input contact. Turn off machine for 2-3 min and restart it. ➤ Cable that connects switch and power board is loosed, tighten it again. ➤ Turn on and off power switch continuously would start overload voltage protection circuit. Turn off machine for 2-3 min and restart it. ➤ 24V relay of main return circuit on power board is not closed or damaged, check 24V power and relay. Replace it with same model series if it's damaged.
Fan is working, abnormal indicator is not lit, sound of HF arc striking cannot be heard, wiping arc welding can not strike arc.	<ul style="list-style-type: none"> ➤ Measure voltage of positive and negative electrode from power board to VH-07 insert of MOS board by multimeter, which should reads DC 308V. <ul style="list-style-type: none"> a) If circuit is broken and silicon bridge is poor contact. b) If some of four high electrolytic (about 470UF/450V) of power panel capacitor is leaking. ➤ There is a green indicator for auxiliary power on MOS board, if it's not lit, auxiliary power is out of work, check fault spot and contact with dealer. ➤ Check if all kinds of connect and insert cable is poor contact. ➤ Check if there is some problem in control circuit, contact with dealer. ➤ Check if control cable of torch is broken.
Abnormal indicator is not lit, sound of HF arc-striking can be heard, no welding output	<ul style="list-style-type: none"> ➤ Cable of torch is broken. ➤ Grounding cable is broken or not connected to work piece. ➤ There is relaxation between output terminal of positive electrode, gas-electricity system output terminal and inner machine.

<p>Abnormal indicator is not lit, sound of HF arc-striking can not be heard, wiping welding can strike arc.</p>	<ul style="list-style-type: none"> ➤ Primary cable of arc-striking transformer is poor contact with power board, tighten it again. ➤ Arc-striking tip is oxidized or distance is too far, get rid of film oxide of burner or adjust the distance between burners to be 1mm. ➤ Switch (sticking/argon-arc welding) is damaged, replace it. ➤ Some of HF arc-striking circuit components is damage, find out and replace it.
<p>Abnormal indicator is lit, no welding output.</p>	<ul style="list-style-type: none"> ➤ Overload current protection may start, please turn off machine first, then restart it after abnormal indicator is off. ➤ Overheat protection may start. It will become normal in 2-3 min. ➤ Inverter circuit may go wrong, please disconnect the power supply plug of the main transformer on MOS board (close to insert of fan VH-07) then restart the machine. <p>(1) If abnormal indicator is still on, turn off machine and disconnect power supply plug of HF arc-striking power source (close to insert of fan VH-07), then restart machine:</p> <ul style="list-style-type: none"> a) If abnormal indicator is still on, some field distors on MOS board are damaged, find out and replace them with same model. b) If abnormal indicator is off, up-slope transformer of HF arc-striking circuit is damaged, replace it. <p>(2) If abnormal indicator is off:</p> <ul style="list-style-type: none"> a) Maybe transformer on middle board is damage, measure primary inductance volume and Q value of main transformer by inductance bridge ($L=0.9-1.6mH$ $Q>35$). If value is too low, please replace it. b) Maybe secondary rectifier tube of transformer is damaged, find out faults and replace rectifier tube with same model. <ul style="list-style-type: none"> ➤ Maybe feedback circuit is open.
<p>When welding aluminum, can not break oxidized film</p>	<ul style="list-style-type: none"> ➤ Wrong welding value. ➤ Pulse duty too low. ➤ Twice inverter MOSFET broken.
<p>Stick is burnt out</p>	<p>Pulse duty is too high, reduce it.</p>

Appendix I Circuit Diagram

TIG 200CT

